

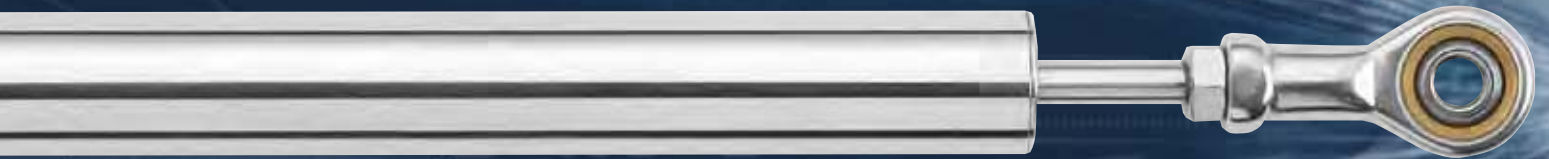

**QSS**  
SENSORS AND COMPONENTS  
QSS Quality Systems Solutions GmbH  
Aemststrasse 5  
CH-8344 Bäretswil  
T 0041 44 242 0000  
F 0041 44 242 0010  
info@qss-solutions.ch  
www.qss-solutions.ch

# Displacement sensors



including **myLVDT** A special kind of service

## World leaders in linear measurement...

Solartron Metrology is a world leader in the innovation and manufacture of precision digital and analogue displacement sensors, dimensional gauging probes, optical linear encoders and associated instrumentation.



### Over 60 years service to industry

Solartron Metrology's origins go back to 1946 with a UK company, Farrol Research and through successive acquisitions by Sangamo Weston, Schlumberger, management, Roxboro Group and AMETEK. We have been known as Sangamo Weston Controls, Sangamo Transducers, Schlumberger Industries Transducer Division and ultimately, Solartron Metrology.

## Global strength. Local support.

With sales offices in Europe, the Americas, and Asia, and distributors in over 30 countries worldwide, our global network ensures that wherever you are a Solartron Metrology specialist is at hand to provide local service and support. Headquartered in the UK, around 90% of our production is exported.



## Quality to the core.

The inherent reliability of Solartron Metrology precision technologies provides consistently accurate performance whilst reducing the cost of ownership. Continuous investment in design and manufacturing ensures that Solartron sensors continue to match and often exceed the expectations of users in industry, research and aerospace.

## Where specials come as standard.





Solartron Metrology offer a broad range of both analogue and digital measurement solutions and associated electronics, some capable of withstanding the most extreme environments. Our plug and go Orbit3 digital network is astonishingly simple to configure and use and with the introduction of our MyLVDT specials service, our commitment to customer support extends further than any other manufacturer.

Rest assured that wherever you are, whatever your application, we have the technology, the commitment and the resources to help you make it better.



Solartron Metrology is part of AMETEK, a leading global manufacturer of electronic instruments and electric motors.

# Contents

Capability, quality, technology and choice World leading expertise			4
Markets and applications Position measurement solutions			10
5 mm to 300 mm High performance sensors		S series 	12
5 mm to 150 mm Rugged sensors for harsh environments		SR series 	14
3 mm to 50 mm Compact and accurate LVDTs		Optimum series 	16
2 mm to 20 mm Miniature and fast LVDTs		SM series MD series DF series 	18
Sensor digital network RS232, USB and ethernet interfaces		orbit3 	20
12 mm and 25 mm Linear encoders with sub micron accuracy		LE series 	23
Stand-alone displays and controllers Single and dual channel, limits, I/O, data logger...		SI 1000 SI 3000 	24
Precision high bandwidth signal conditioning modules ±5 Vdc, 0-10 Vdc, 4-20 mA, TTL output		OD series DRC, ATM BICM 	26
Dimensional drawings			28
Other Solartron Metrology products		Gauging Specialist gauging Gemco series 	43

# Performance products with a twist...

Configure our standard range to create the optimum measurement solution for your application

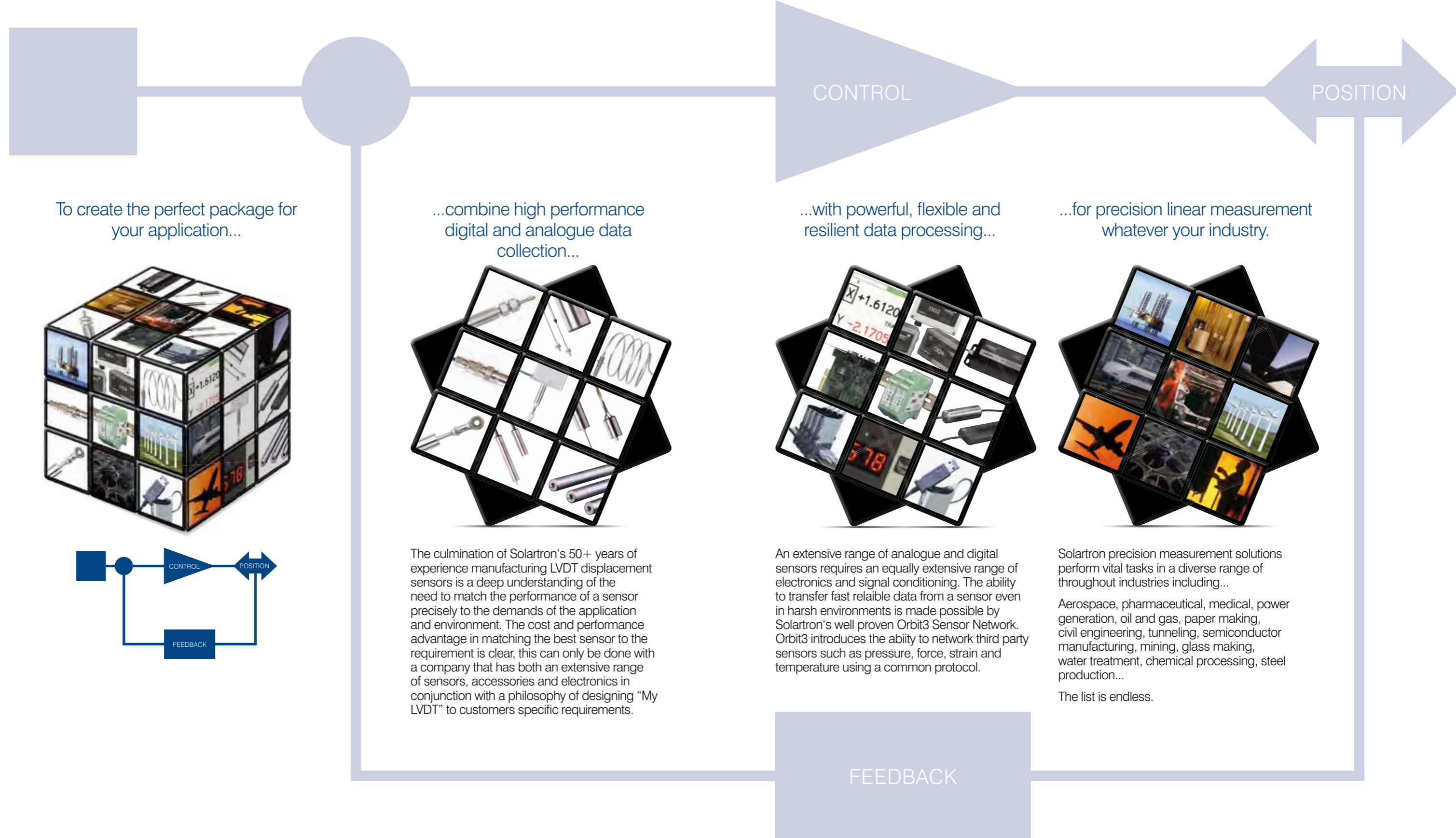

To create the perfect package for your application...

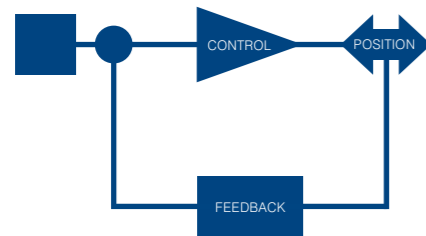

...combine high performance digital and analogue data collection...



The culmination of Solartron's 50+ years of experience manufacturing LVDT displacement sensors is a deep understanding of the need to match the performance of a sensor precisely to the demands of the application and environment. The cost and performance advantage in matching the best sensor to the requirement is clear, this can only be done with a company that has both an extensive range of sensors, accessories and electronics in conjunction with a philosophy of designing "My LVDT" to customers specific requirements.

...with powerful, flexible and resilient data processing...



An extensive range of analogue and digital sensors requires an equally extensive range of electronics and signal conditioning. The ability to transfer fast reliable data from a sensor even in harsh environments is made possible by Solartron's well proven Orbit3 Sensor Network. Orbit3 introduces the ability to network third party sensors such as pressure, force, strain and temperature using a common protocol.

...for precision linear measurement whatever your industry.



Solartron precision measurement solutions perform vital tasks in a diverse range of throughout industries including...

Aerospace, pharmaceutical, medical, power generation, oil and gas, paper making, civil engineering, tunneling, semiconductor manufacturing, mining, glass making, water treatment, chemical processing, steel production...

The list is endless.

## A special kind of service

At Solartron Metrology our vastly experienced design team has for many years, collaborated with customers' design teams to produce successful and cost effective bespoke measurement solutions.

Drawing on this experience MyLVDT formalises this approach and puts our expertise in the spotlight.

With a knowledge base of sensor, electronics and software design spanning decades, we can work with you to identify, design, prototype and manufacture a novel solution to fit your application and your budget.

If you have a seemingly intractable linear measurement problem we need to talk.

**MyLVDT: a special kind of service**

## Your input...

**Measuring range**  
1 mm to > 1 m

**Accuracy**  
Microns

**Sensor dimensions**  
Sub miniature to long range

**Environmental protection**  
Temperature  
Vibration  
Shock  
Hermetic  
Submersible...

**Mechanical**  
Carrier  
Springs  
Rod ends

**Electrical**  
Power supply  
Internal electronics  
External electronics  
Output type

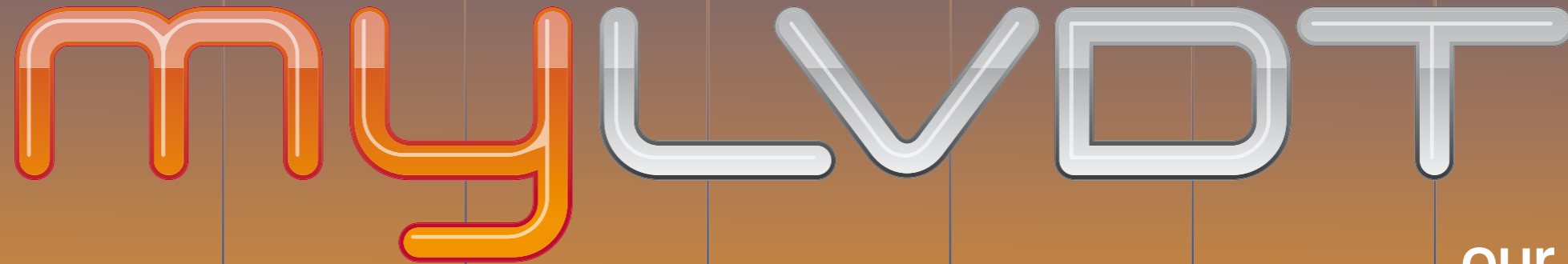

## ...our output.

**Engineering**  
Coil design  
Mathematical modelling  
3D CAD

**Specials as standard**  
High speed modular design

**Manufacture**  
Advanced machine shop  
Precision coil winding

**Networked solutions**  
Orbit®

**Quality systems**  
ISO 9000  
ATEX

**Global technical support**  
Asia, Europe, USA

## The path to measurement perfection



Consultation



Specification agreement



3D modelling



Prototyping

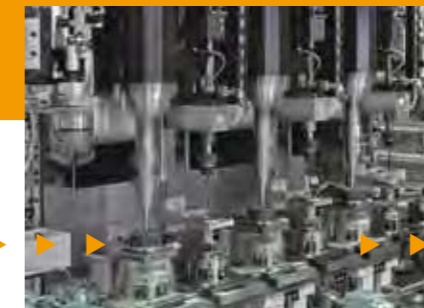

Manufacture



**Result:** the precise position sensing package for your exact application

# Quality to the core

Simplicity of operation is the main strength of an LVDT, but to produce a reliable and stable sensor requires meticulous attention to detail in its design and manufacture.

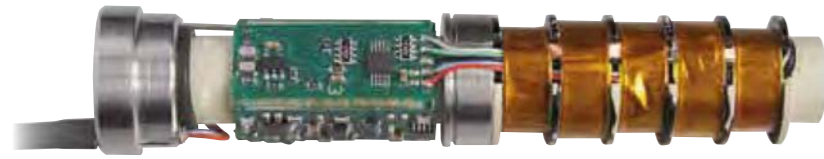

Highly stable and clean signal conditioning is essential to get the best performance from an LVDT sensor.

Precision wound coils on highly stable bobbins provide excellent linearity and temperature coefficients.



Mu metal screening gives improved protection against electromagnetic fields on some models.



Electron beam welding on all submersible sensors ensures that there is no contamination within the weld that can lead to corrosion.

Solartron's sensor bodies, core carriers and end caps are made from high grade stainless steel.

## A universal truth: data is only of true value when it is processed from a reliable source...

Integral electronics, high performance external electronics, single or multichannel digital communication from absolute displacement sensors provide the ultimate in system performance.



## Tried, tested and approved...



# Core technology

## Principle of operation

An LVDT Displacement Sensor works by moving the core through the body. The position of the core within the body is detected by coils wound on the bobbin.

The coils are supplied with an ac signal and return an ac signal. This signal is then processed by conditioning electronics to provide a measure of the core position.

The body is normally mounted on the static part of an element and the core attached to the moving part.

## Core benefits

### Absolute positioning

Does not lose position during a power down and does not suffer from over speeding like incremental sensors making it ideal for closed loop control.

### Ruggedness

With good choice of materials and design the Displacement Sensor is perfect for harsh environments.

### Infinite resolution

Ideal for detecting very small changes of position when used with Solartron's precision signal conditioning.

### Repeatable

Sub micron repeatability provides perfect limit or close-loop control.

### Dynamic response

Free core sensors, fitted with low mass cores provide excellent dynamic response up to several kHz when used with Solartron's precision signal conditioning.

### Flexibility

Solartron's design engineers can design sensors to fit your application. (MyLVDT).

## Conventional LVDT

When the core is in a central position, the coupling from the primary ( $V_{EXC}$ ) to each secondary is equal, so  $V_A = V_B$  and the output  $V_{OUT} = 0$ . As the core is displaced  $V_A$  differs from  $V_B$ , and the output  $V_{OUT}$  changes in magnitude and phase in proportion to the movement.

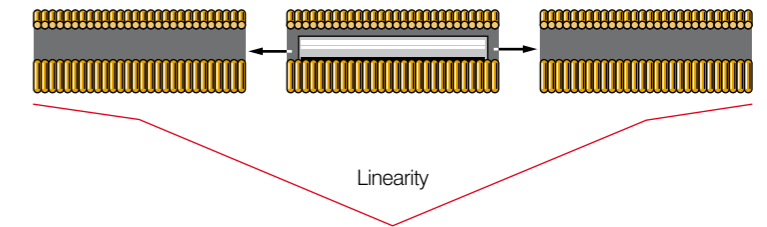

## Solartron LVDT

Solartron Metrology's continuous development of precision bobbin mouldings and multi chambered coil windings ensure excellent linearity and thermal stability throughout the range.

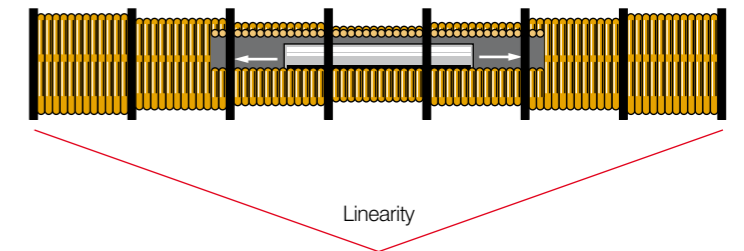

## Solartron Orbit3 digital sensors

Solartron Metrology digital sensors are calibrated using a traceable interferometer and are issued with a calibration certificate. All digital sensors are fitted with integrated electronics, which store information such as probe ID, range, calibration error, etc. Digital sensors provide superior performance compared to traditional analogue sensors. Performance figures quoted in this catalogue include all mechanical errors within the probe head together with any errors in the electronics interface modules.



# Applications in industry

## Position feedback

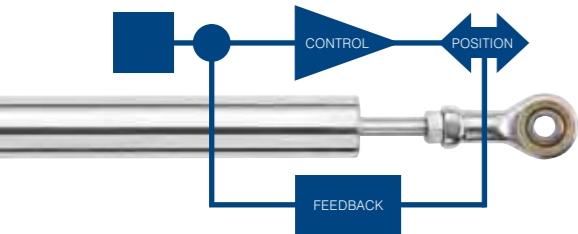

### Energy

Power generation  
Wind turbine  
Oil and gas



### Transport

Aerospace  
Rail  
Off-highway  
Automotive  
Drones



## Examples

- ▶ Position feedback
- ▶ Level measurement
- ▶ Machine alignment
- ▶ Assembly checking
- ▶ Injection monitoring
- ▶ Close loop control
- ▶ Tool positioning
- ▶ Movement control
- ▶ Lift position control
- ▶ Distance control



### Fluid power

Hydraulics  
Servo valves  
Pneumatics  
Solenoids



### Automation

Assembly  
Robotics  
Electronics  
Mechatronics  
Metal forming

# Applications in laboratory and test

## Displacement measurement

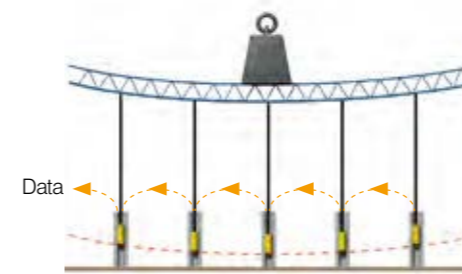

## Examples

- ▶ Cracks monitoring
- ▶ Structure monitoring
- ▶ Alignment measurement
- ▶ Deformation measurement
- ▶ Expansion displacement
- ▶ Contraction displacement
- ▶ Crush displacement
- ▶ Deflection measurement
- ▶ Research

### Test machines

Traction  
Compression  
Creep & Stress  
Flexion  
Fatigue



### Structures

Building  
Bridge  
Barrage  
Cracks  
Soil

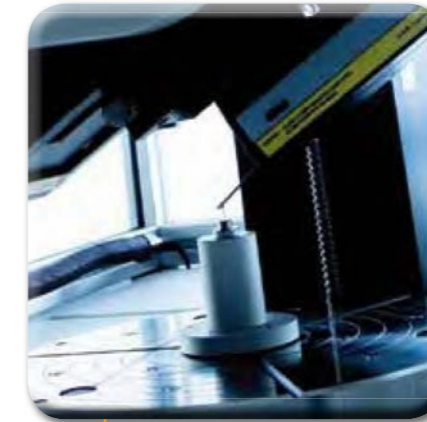

### Metrology

Hardness  
CMM  
Calibrators  
Dimension



### Bench test

Wood  
Metal  
Aerospace  
Agronomy  
Automotive

# S series

## High performance displacement sensors

- ▶ <0.2% Linearity
- ▶ 19mm Stainless Steel body
- ▶ IP65 and IP67 option
- ▶ Excellent measuring range to body length
- ▶ Multiple output options with integrated electronics
- ▶ Large bore to core clearance for ease of installation
- ▶ Excellent magnetic screening
- ▶ Wide range of signal conditioning and instrumentation

The S Series Displacement Sensor is the cumulation of many years' experience gained from Solatron's pedigree of a history of excellent displacement sensors coupled with attention to market feedback. The result is a large range of sensors both "off the shelf" and "customer specials" that is better able to satisfy today's demanding manufacturing and research applications.

The S base series has been expanded to include the SR (Rugged range).



Standard output options
▶ LVDT
▶ ±5V DC
▶ ±10V DC
▶ 0-5V DC
▶ 5-0V DC
▶ 0-10V DC
▶ 10-0V DC
▶ 4-20 mA
▶ 20-4 mA
▶ Solartron Orbit (Digital)
▶ TTL

Mechanical options
▶ Free Core
▶ Free Core /Carrier
▶ Guided Core
▶ Tip
▶ Spring
▶ Universal Joints

Connection options
▶ Cable (wire ends)
▶ Cable + Connector
▶ Axial Connector
▶ PIE (Orbit digital only)

For non-standard sensors please contact your local Solatron Sales Office or Distributor (see back cover)

Also see...	
Sensor dimensions/drawings	Page 28 ▶
Orbit interface dimensions/drawings	Page 41 ▶

Generic Sensor types	AS/2.5	AS/5	AS/7.5	AS/10	AS/15	AS/25	AS/50	AS/75	AS/100	AS/150
LVDT	VS/2.5	VS/5	VS/7.5	VS/10	VS/15	VS/25	VS/50	VS/75	VS/100	VS/150
Voltage Output (±DC Bipolar)	VS/2.5	VS/5	VS/7.5	VS/10	VS/15	VS/25	VS/50	VS/75	VS/100	VS/150
Voltage Output (DC Unipolar)	VS/5	VS/10	VS/15	VS/20	VS/30	VS/50	VS/100	VS/150	VS/200	VS/300
Current Output (4-20mA)	IS/5	IS/10	IS/15	IS/20	IS/30	IS/50	IS/100	IS/150	IS/200	IS/300
Digital Output (Orbit)	DS/5	DS/10	DS/15	DS/20	DS/30	DS/50	DS/100	DS/150	DS/200	DS/300

Measurement	AS/2.5	AS/5	AS/7.5	AS/10	AS/15	AS/25	AS/50	AS/75	AS/100	AS/150
Measurement Range (LVDT/±DC) (mm)	±2.5	±5	±7.5	±10	±15	±25	±50	±75	±100	±150
Measurement Range (4-20mA/DC/ORBIT) (mm)	5	10	15	20	30	50	100	150	200	300
Pre-travel ±0.5 mm (Guided Versions only)	2.0	3.0	1.6	3.1	6.7	6.9	4.9	5.0	8.8	16.2
Post Travel ±0.5 mm (Guided Versions only)	4.3	5.3	3.9	5.6	9.0	9.3	7.3	7.4	11.1	18.6
Linearity (% FSO)	<0.20									<0.25
Resolution μm <sup>1</sup>	<0.1	<0.1	<0.1	<0.2	<0.2	<0.3	<0.5	<0.7	<1.0	<2.0
Temperature Coefficients (%FSO/°C) LVDT	<0.02	<0.01	<0.01	<0.01	<0.01	<0.01	<0.01	<0.015	<0.01	<0.01
Temperature Coefficients (%FSO/°C) DC/4-20mA	< 0.01									

Mechanical	AS/2.5	AS/5	AS/7.5	AS/10	AS/15	AS/25	AS/50	AS/75	AS/100	AS/150
Body diameter (mm)	19 (+0.0, -0.2)									
Case material	300 Series Stainless Steel									
Core material	Nickel Iron									
Tip Force ±20% (Horizontal at middle of range) N	1.1	1.0	1.0	1.1	1.2	1.5	2.1	1.9	2.3	2.6
Cable Type	F.E.P.									
Standard cable Length (m)	3									
Standard cable Style	B									
Nominal Mass (g) LVDT	58	66	67	80	92	110	153	167	243	344
Nominal Mass (g) (4-20mA/DC)	72	80	81	94	106	124	167	181	257	358
Nominal Mass of Core (g)	2.6	5.0	5.8	7.2	6.4	6.6	9.0	9.0	9.0	9.0

Environment	AS/2.5	AS/5	AS/7.5	AS/10	AS/15	AS/25	AS/50	AS/75	AS/100	AS/150
Temperature (Standard LVDT) (°C)	-40 to +120									
Temperature (HT LVDT) (°C)	-40 to +200									
Operating/Storage Temperature (4-20mA/DC) (°C)	0 to +65 / -20 to 85									
Sealing	IP65 or IP67									
Vibration Sinusoidal	1 to 10g rms linear 10 to 50 Hz & 10g rms 50Hz to 1kHz									
Vibration Random	DO160F Curve D									
Shock	Drop test from 1m onto hard surface									

Electrical Interface (LVDT)	AS/2.5	AS/5	AS/7.5	AS/10	AS/15	AS/25	AS/50	AS/75	AS/100	AS/150
Energising Voltage	1-10 (Vrms)									
Energising Current at 5kHz (mA/V)	1.0	2.6	2.2	0.7	1.5	0.5	0.6	2.5	1.65	1.83
Sensitivity at 5kHz ±10% mV/V/mm	144	178	121	76	60	21.5	15	10.5	6.9	3.9

Electrical Interface (4-20mA & DC)	AS/2.5	AS/5	AS/7.5	AS/10	AS/15	AS/25	AS/50	AS/75	AS/100	AS/150
Input	10 to 30 V or 4-20mA loop powered									
Noise (DC Output) measured in 500Hz	<0.2 mV									
Output Change with Power Supply Variation	<0.5 mV									
Bandwidth (-3dB)	500Hz									

Electrical Interface (Orbit)	AS/2.5	AS/5	AS/7.5	AS/10	AS/15	AS/25	AS/50	AS/75	AS/100	AS/150
Bandwidth	Up to 460 Hz (selectable)									
Output	Solartron Orbit									
Power (VDC)	5±0.25 @ 0.06A									
Sealing	IP43									
Weight (grams) Probe Interface electronics	52									
T connector (including DIN rail adaptor)	46									

Note 1: Resolution specification is only applicable to ORBIT digital sensors. The resolution of LVDT sensors is effectively infinite and is only limited by the conditioning electronics.

Cable Style A comprises of individual twisted cores. Cable Style B comprises a sheathed and screened cable

# SR series

High performance rugged displacement sensors

- ▶ Rugged construction for use in demanding environments
- ▶ Pressure tested to 100 bar
- ▶ 0.2% Linearity
- ▶ 19mm Stainless Steel body and core carrier
- ▶ IP68 with axial connector
- ▶ Multiple output options with integrated electronics
- ▶ Screw Mount Options
- ▶ Excellent magnetic screening



Solartrons well proven and popular S Series provided the ideal platform for the SR ruggedized sensor range, specifically developed for challenging environments in lab & test and process control applications.

Environmental ratings for the SR series have been increased to IP68 or fully Hermetically sealed. Extra high temperature versions are also available in LVDT format and Orbit Digital (sensor only).

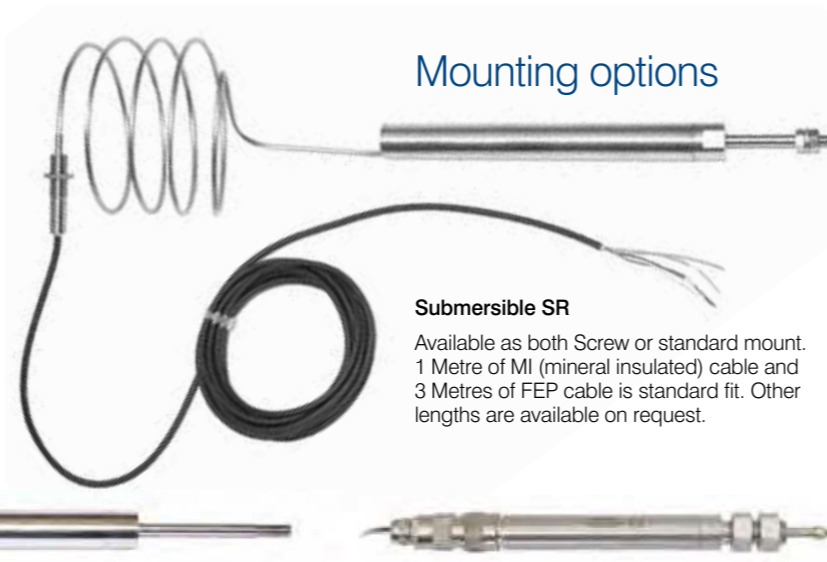

## Mounting options

### Submersible SR

Available as both Screw or standard mount. 1 Metre of MI (mineral insulated) cable and 3 Metres of FEP cable is standard fit. Other lengths are available on request.

### Standard Mount

Standard Mount sensors are available as Free Core or Guided armature. Spring Return is an optional extra with an external spring on guided versions. Measuring ranges (total) 5mm to 300mm.

### Screw Mount

Screw Mount sensors have a Captive Armature with an anti-rotation guide and an internal spring. Measuring ranges (total) from 5mm to 150mm.

### Standard output options

- ▶ LVDT
- ▶ ±5V DC
- ▶ ±10V DC
- ▶ 0-5V DC
- ▶ 5-0V DC
- ▶ 0-10V DC
- ▶ 10-0V DC
- ▶ 4-20 mA
- ▶ 20-4 mA
- ▶ Solartron Orbit (Digital)

### Mechanical options

- ▶ Free Core
- ▶ Free Core /Carrier
- ▶ Guided Core
- ▶ Captive Guided Core
- ▶ Tip
- ▶ Spring

For non-standard sensors please contact your local; Solartron Sales Office or Distributor (see back cover)

### Connection options

- ▶ Cable (wire ends)
- ▶ Cable + Connector
- ▶ MI Cable
- ▶ Axial Connector
- ▶ PIE (Orbit digital only)

### Generic sensor Types

LVDT	RAS/2.5	RAS/5	RAS/7.5	RAS/10	RAS/15	RAS/25	RAS/50	RAS/75
Voltage Output (±DC Bipolar)	RVS/2.5	RVS/5	RVS/7.5	RVS/10	RVS/15	RVS/25	RVS/50	RVS/75
Voltage Output (DC Unipolar)	RVS/5	RVS/10	RVS/15	RVS/20	RVS/30	RVS/50	RVS/100	RVS/150
Current Output (4-20mA)	RIS/5	RIS/10	RIS/15	RIS/20	RIS/30	RIS/50	RIS/100	RIS/150
Digital Output (Orbit)	RDS/5	RDS/10	RDS/15	RDS/20	RDS/30	RDS/50	RDS/100	RDS/150

### Measurement

Measurement Range (LVDT/±DC) (mm)	±2.5	±5	±7.5	±10	±15	±25	±50	±75
Measurement Range (4-20mA/DC/ORBIT) (mm)	5	10	15	20	30	50	100	150
Pre-travel ±0.5 mm (Guided Versions only)	1.5	2.7	2.5	3.4	6.4	6.6	4.6	4.7
Post Travel ±0.5 mm (Guided Versions only)	1.1	1.7	1.4	2	4.5	5.3	3.8	3.7
Linearity (% FSO)	0.20							
Resolution μm <sup>1</sup>	<0.1	<0.1	<0.1	<0.2	<0.2	<0.3	<0.5	<0.7
Temperature Coefficients (%FSO/°C) LVDT	<0.022	<0.016	<0.032	<0.031	<0.013	<0.015	<0.025	<0.026
Temperature Coefficients (%FSO/°C) DC/4-20mA	<0.03							

### Mechanical

Body diameter (mm)	19 (+0.0, -0.2)							
Case material	300 Series Stainless Steel							
Tip Force ±20% (Horizontal at middle of range) N	1.0	0.9	1.0	1.1	1.2	1.5	2.1	1.9
Cable Type	Mineral Insulated + F.E.P							
Standard cable Length (m)	3							
Standard cable Style	TYPE MIL-C-26482 Series 1							
Nominal Mass (g) LVDT	59	65	72	81	93	110	151	190
Nominal Mass (g) (4-20mA/DC)	76	87	95	101	121	136	176	216
Nominal Mass of Core (g)	2.6	5.0	5.8	7.2	6.4	6.6	9.0	9.0

### Environment

Operating/Storage Temperature (LVDT) (°C)	-40 to +120 / -40 to +120							
Operating/Storage Temperature (4-20mA/DC) (°C)	0 to +65 / -20 to 85							
Sealing	IP68 with axial connector. Sealed up to 100 bar with MI cable							
Vibration Sinusoidal	1 to 10g rms linear 10 to 50 Hz & 10g rms 50Hz to 1kHz							
Vibration Random	DO160F Curve D							
Shock	Drop test from 1m onto hard surface							

### Electrical Interface (LVDT)

Energising Voltage	1-10 (Vrms)							
Energising Current at 5kHz (mA/V)	1.0	2.6	2.2	0.7	1.5	0.5	0.6	2.5
Sensitivity at 5kHz ±10% mV/V/mm	139	125	59.5	60	52.5	17.7	11.8	8.4

### Electrical Interface (4-20mA & DC)

Input	10 to 30 V or 4-20mA loop powered							
Noise (DC Output) measured in 500Hz	<0.2 mV							
Output Change with Power Supply Variation	<0.5 mV							
Bandwidth (-3dB)	500Hz							

### Electrical Interface (Orbit)

Bandwidth	Up to 460 Hz (selectable)							
Output	Solartron Orbit							
Power (VDC)	5±0.25 @ 0.06A							
Sealing	IP43							
Weight (grams) Probe Interface electronics T connector (including DIN rail adaptor)	52 46							

Note 1: Resolution specification is only applicable to ORBIT digital sensors. The resolution of LVDT sensors is effectively infinite and is only limited by the conditioning electronics.

### Also see...

Sensor dimensions/drawings	Page 32	▶
Orbit interface dimensions/drawings	Page 41	▶



# Optimum series

## Narrow bodied high performance sensors

- ▶ Good measurement range to body length ratio
- ▶ Small body diameter
- ▶ Larger radial bore clearance
- ▶ Rugged Construction

The Optimum Series of LVDT sensors is an ideal choice for process control and research applications. The free core variants are designed for precise linear positioning and measurement of moving parts where zero friction and hysteresis is required within a restricted space.

The free core version is available with an optional light weight core for mounting on to small, rapidly moving structures without affecting their performance and integrity - important in some control applications.

The lightweight core has a 1.9mm diameter which improves core to bore clearance, making alignment easier. A light titanium core carrier can be supplied on request.

The Optimum is also available as a guided product and with universal joints either as an LVDT or Digital product for use in applications where it is not possible to mount the core and carrier on the moving part.

*Note: the Optimum can be wired as either differential output or ratiometric (except OP/10)*



Sensor					
LVDT Free Core	OP/1.5/F	OP/6/F	OP/10/F	OP/12.5/F	OP/25/F
LVDT Guided	OP/1.5/G	OP/6/G	OP/10/G	OP/12.5/G	OP/25/G
ORBIT Digital Guided	DO/3	DO/12	DO/20	DO/25	DO/50
Measurement					
Measurement Range (LVDT/Digital) (mm)	±1.5 / 3	±6 / 12	±10 / 20	±12 / 24	±25 / 50
Total mechanical travel ±0.5 (mm)	3.6	15.2	23.2	29.8	TBA
Pre-travel (guided only) (mm)	1.78	1.53	1.53	2.33	TBA
Linearity (% FSO)	<0.25				
Resolution $\mu\text{m}^1$	<0.1		<0.2		<0.4
Temperature Coefficients (%FSO/°C)	<0.05%				
Mechanical					
Body diameter (mm)	9.52				
Case Material	400 Series Stainless Steel				
Tip Force ±20% (Horizontal at middle of range) N	66	94	94	93	TBA
Cable Type	F.E.P.				
Standard cable Length (m)	5 (max)				
Standard cable Style	A or B				
Nominal Mass (g)	7	12	12	20	TBA
Nominal Mass of Moving Parts (g)	1.5	2.5	2.0	3.5	TBA
Environment					
Operating Temperature (Sensor) (°C)	-40 to +150				
Storage Temperature (Sensor) (°C)	-40 to +150				
Sealing	IP65				
Electrical Interface (LVDT)					
Energising Voltage	1-10 (Vrms)				
Energising Current at 5kHz (mA/V)	6	4.5	3.2 at 20 kHz	7	TBA
Frequency Response (-3db) Hz	Depends on Electronics and Sensor Configuration				
Sensitivity at 5kHz ±10% mV/V/mm	108	78	85 at 20 kHz	69	TBA
Zero phase frequency (kHz)	13.1	24.1	>30	24.8	TBA
Electrical Interface (Orbit)					
Bandwidth	Up to 460 Hz (selectable)				
Output	Solartron Orbit				
Power (VDC)	5±0.25 @ 0.06A				
Sealing	IP43				
Weight (grams)	Probe Interface electronics		52		
	T connector (including DIN rail adaptor)		46		

Note 1: Resolution specification is only applicable to ORBIT digital sensors. The resolution of LVDT sensors is effectively infinite and is only limited by the conditioning electronics.

**Cable Style A** comprises of individual twisted cores  
**Cable Style B** comprises a sheathed and screened cable

Also see...	
Sensor dimensions/drawings	Page 37 ▶
Orbit interface dimensions/drawings	Page 41 ▶

# SM/MD/DF series

Miniature displacement sensors

## SM

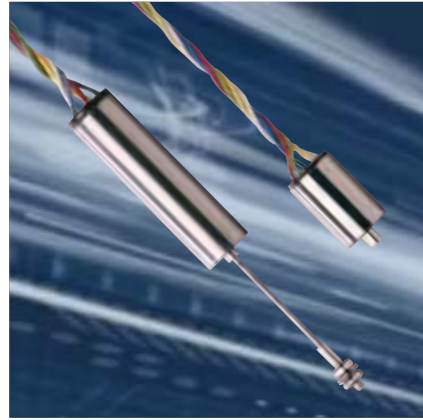

- ▶ Rugged construction
- ▶ Short body length
- ▶ Good performance

SM sensors cover two standard types in two measurement ranges  $\pm 1$ mm and  $\pm 3$ mm. They are designed for measuring displacement in applications where infinite resolution and precise repeatability is required in a very small size.

The coils are wound on a PPS (40% GL) former and housed in a stainless steel case. The epoxy bonded construction makes the device suitable for operation in wet and oily environments and in applications with high levels of mechanical stress.

The core carrier assembly moves friction free within the sensor, an alternative option where the core is provided threaded at both ends is available allowing the user to manufacture their own carrier interface. Recommended carrier material is titanium.

## MD



- ▶ Small diameter
- ▶ Right angle cable outlet option
- ▶ Low core weight
- ▶ Screened cable

The small case diameter (6mm and 8mm) allows for easy installation in confined spaces. A right angle output facility is available as a retrofit for the 8mm version.

The low core weight makes this range ideal for use in low inertia systems. Cross talk is prevented by the screened cable, which also allows for multiple use of these sensors in close proximity.

## DF

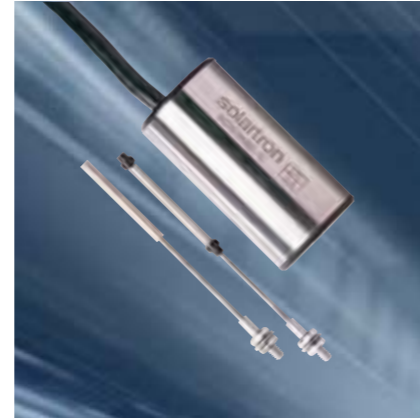

- ▶ Measurement range to 10mm
- ▶ High Output
- ▶ Excellent repeatability
- ▶ Low power

The DF dc miniature displacement sensor has a friction-free core and the DFg has a free guided core incorporating Delrin bearings. All types incorporate a linear variable differential transformer (LVDT) as the measuring source together with oscillator, demodulator and filter providing a self-contained unit accepting a DC input and providing a DC output relative to armature position.

With high linearity and low mass of moving parts, these are ideally suited to applications in civil, mechanical, chemical and production engineering. Also, when mounted in a suitable load-sensitive member such as a proof ring or diaphragm, they can provide load or pressure measurement.

Sensor											
LVDT with Free Core	SM1	SM3	M6D1	MD1	MD2.5	MD5	MD10	-			
Half Bridge (HB) with Free Core	-		M6DH1	MD1H	MD2.5H	MD5H	MD10H	-			
DC Output with Free Core								DF1	DF2.5	DF5	
DC Output with Guided Core								DFg1	DFg2.5	DFg5	
Measurement											
Measurement Range (mm)	$\pm 1$	$\pm 3$	$\pm 1$	$\pm 1$	$\pm 2.5$	$\pm 5$	$\pm 10$	$\pm 1$	$\pm 2.5$	$\pm 5$	
Linearity (% FSO)	0.25		-					0.30			
Linearity (% Reading)	-		0.5					-			
Resolution $\mu\text{m}^1$	<0.1						<0.2	see Note 1			
Temperature Coefficients (%FSO/°C)	<0.03%		<0.01%						<0.025%		
Mechanical											
Body diameter (mm)	9.52		6h6	8h6			19.0				
Case Material	400 Stainless Steel										
Cable Type	PU										
Standard cable Length (m)	0.5		2				3				
Standard cable Style	A					B					
Nominal Mass (g)	6.0	8.0	2.6	5.0	7.6	8.5	13.0	26.0	26.0	30.0	
Nominal Mass of Moving Parts (g)	0.50	1.50	0.10	0.20		0.30	0.70	1.00	1.00	1.20	
Environment											
Operating Temperature (°C)	-40 to +85			-10 to + 80				-5 to + 70			
Storage Temperature (°C)	-40 to +100			-40 to +105				-10 to + 80			
Sealing	Splash Proof										
Electrical Interface											
Energising Voltage	1-10 (Vrms)						17-24 (VDC)				
Energising (LVDT) Current at 5kHz (mA/V)	3.8	1.8	3.0	1.8	2.0	1.0	0.6	-			
Energising Current (HB) at 10kHz (mA/V)	-		1.2	1.0	-	1.2	-	-			
Energising Current (DC) at 10V (mA)								10	13		
frequency Response (-3db) Hz	Depends on Conditioning Electronics										
Sensitivity at 10VDC $\pm 10\%$ mV/V/mm											
								75	54		
Sensitivity at 5kHz $\pm 10\%$ mV/V/mm	142	136	269	210	150	105	33	-			
Sensitivity (HB) at 10kHz $\pm 10\%$ mV/V/mm	-		88	83	82	51	33	-			

Note 1: Resolution specification is only applicable to ORBIT digital sensors. The resolution of LVDT sensors is effectively infinite and is only limited by the conditioning electronics.

**Cable Style A** comprises of individual twisted cores  
**Cable Style B** comprises a sheathed and screened cable

Also see...

Dimensions and drawings

Page 38 ▶



The complete Orbit3 product range is vast. For full information refer to Solartron's Orbit3 catalogue or our website.

The Orbit3 Digital Network system for single or multiple channels is the solution to get fast and reliable data from displacement sensors and, for example, third party pressure, temperature and rotary sensors, quickly and easily into a computer or PLC.

### Orbit software

Solartron provide an Orbit library fully compatible with Windows 7 and all 64 bit Windows operating systems. OrbMeasureLite is an out of the box application for small networks which includes seamless interfacing to Excel.

### Orbit measurement modes

Orbit supports a number of different measurement modes for different applications. In Standard mode each module is read as required whereas Dynamic mode provides a means of rapidly reading synchronised modules up to 3096 readings per second.

### Network components

Attached to the end of each sensor is a hot swappable PIE (Probe Interface Electronics) which clips into a T-CON network connector fitted with a detachable 35 mm DIN rail mount.

The completed module simply pushes together with other modules to form an integrated scaleable network.

A power supply interface module (PSIM), controller modules and interface modules complete the package (see over for details).



Orbit3 modules simply push together to provide a compact and elegant digital network

Indicator lamps show power within limits and data transmission active



**PIE**  
Strong light weight body with screening against electrical interference to EN61000-6-2



**T-CON**  
Strong lightweight construction holding the sensor address to enable HOT SWAP facility. Improved clamping and IP65 option



**DIN Rail mount** as standard. Removeable to enable alternative mounting options

### Controllers

- ▶ USB, RS232 and ethernet interfaces



### Controllers

	USB Interface Module (USBIM)	RS232 Interface Module (RS232IM)	Ethernet Interface Module (ETHIM)
<b>Computer Interface</b>			
Bus	USB 2.0 full speed	RS232 (up to 115.2 kB)	Ethernet
Operating system	Microsoft Windows		
<b>Network Interface</b>			
Number of Orbit modules (with/without PSIM)	150/4	150/0	
Baud rate	187.5 kB, 1.5 MB, 2.25 MB	187.5 kB, 1.5 MB	
Measurement Modes	Standard and Dynamic	Standard	
Typical reading rates (rdgs/sec)	Up to 3906	250	460
<b>Power and Environment</b>			
Current at 4.75 V to 5.25 V DC (mA)	250	62	
Operating Temperature (°C)	0 to +60		

### Modules

- ▶ AIM: for third party sensors
- ▶ SGM: for strain gauges and load cells
- ▶ EIM: for linear encoders and line scales
- ▶ DIOM: for control of inputs and outputs



### Modules

	Analogue Input Module (AIM)	Encoder Input Module (EIM)	Strain Gauge Module (SGM)	Digital input-output Module (DIOM)
<b>Inputs/Outputs</b>				
Input Type	Voltage or Current	Incremental Encoder (TTL)	Strain Gauge	8 channel Input/Output
Input Voltage (VDC)	0-24, 0-10, 0-5, ±10, ±5	max. 30	-	0 to 30
Input Current (mA)	4-20, 0-20, ±20	< 10	-	1 per Channel
Voltage Output	-	-	5V AC	Up to 8, open drain up to 30 V @ 50 mA
<b>Network Interface</b>				
Measurement Modes	Standard/Dynamic			
Linearity (%FSO)	0.05	-	0.02	-
Bandwidth (Hz)	460		-	
<b>Power and Environment</b>				
Current at 4.75 V to 5.25 V DC (mA)	Up to 154 depending on type	49		42
Operating Temperature (°C)	0 to +60			



Solartron Metrology is the world's largest manufacturer of 'pencil' style electronic gauging probes.

Featured here are standard spring push sensors from our Orbit digital range.

Other methods of actuation include pneumatic and vacuum retract with LVDT, half bridge and Orbit variants.

Specialist gauging sensors are also available - visit our web site for details.

Standard spring actuated probes						
Axial Cable Outlet	DP/2/S	DP/5/S	DP/10/S	DP/12/S	DP/20/S	DP10/2/S
Radial Cable Outlet	DPR/2/S	-	DPR/10/S	-	DPR/20/S	-
Body Diameter	8h6					
Measurement Range (mm)	2	5	10	12	20	2
Pre-Travel (mm)	0.15					
Over Travel (mm)	0.85					
Accuracy (% reading)	0.05	0.06	-	0.07	0.05	
Repeatability (µm)	< 0.15					
Tip Force (N) at centre travel ±20%	0.7					
Resolution (µm) - user selectable	< 0.01	< 0.05	-	< 0.01		
Data Speed - user selectable	Up to 3906 readings per second					
Case Material	Stainless steel					
Gaiter	High grade polymer					
Operating Temperature (°C)	-5 to +80					
Sealing	IP65					

## ATM analogue to TTL module

- ▶ Compatible with all Solartron sensors
- ▶ Will not overspeed even at high resolution settings
- ▶ Absolute position constantly accessible
- ▶ Range of resolution and frequency options
- ▶ Status Indication lamps

An alternative interface method to Orbit, the ATM provides a solution to simple PLC interfacing for Solartron sensors.



ATM TTL converter	
Measurement	
Sensor types	Solartron Gauging and Displacement Sensors 0.5 mm to 150 mm depending on sensor
Accuracy (%FSO)	Up to 0.15% reading depending on sensor
Resolution (x4 interpolation)	0.1 µm
Repeatability	<0.15 µm depending on sensor
Electrical	
Power	+5 ±0.25 VDC @ 100 mA
Output Signal	A and B, /A and /B TTL square waves RS422 levels
Output frequency (kHz)	50, 100, 125, 250, 360 & 500 (factory selectable)
Bandwidth	100 Hz
Environmental (electronics)	
Sealing	IP43 for ATM Module
EMC	Emmissions: EN61000-6-3 Susceptibility: EN6100-6-2
Operating temperature (°C)	0 to +60
Storage temperature (°C)	-20 to +70

Refer to product manual 502724 for details of operation – contact sales office/web site



- ▶ Orbit compatible
- ▶ 12 and 25 mm measuring range
- ▶ Spring, free, pneumatic and cable operation
- ▶ <0.4µm accuracy
- ▶ <0.02 resolution
- ▶ TTL output

The Linear Encoder range of measuring sensors uses a highly stable and accurate optical sensor in conjunction with precisely manufactured bearings for use in applications requiring consistent sub micron measurement accuracy.

Linear encoder	LE12		LE25	
Output	Orbit	TTL	Orbit	TTL
Measurement				
Measurement range (mm)	12		25	
Mechanical travel (mm)	13		26	
Accuracy (µm)	±0.4	±0.5	±0.4	±0.5
Repeatability (µm)	0.1			
Resolution (µm)	0.5	depends on electronics	0.5	depends on electronics
Reference mark position (mm)	3 approximately from end stop			
Maximum gauging speed (m/s)	0.5	See table below	0.5	See table below
Tip Force (N) Up/Down/Horizontal	0.1/0.6/0.5			
Temperature coefficient (µm/°C)	-0.35 to -0.5		-0.4 to -0.7	
Mechanical				
Scale material	Quartz			
Shaft material	Stainless Steel			
Gaiter material	Viton			
Environment				
Operating Temperature (°C)	+10 to +50			
Storage Temperature (°C)	-20 to +70			
IP rating	Option 50/65 for spring actuation, 65 for pneumatic			
Electrical Interface (Orbit)				
Bandwidth	Up to 460 Hz (selectable)			
Output	Solartron Orbit			
Power (VDC)	5±0.25 @ 0.06A			
Sealing	IP43			
Weight (grams)	Probe Interface electronics	52		
	T connector (including DIN rail adaptor)	46		

TTL output gauging speeds			
Probe signal period (µm)	Interpolation	Quad edge period (µm)	Maximum gauging speed (m/s)
0.4	X25	0.1	0.5
0.2	X50	0.05	0.5
0.1	X100	0.025	0.4
0.05	X200	0.0125	0.2

Also see...	
Sensor dimensions/drawings	Page 39 ▶
Orbit interface dimensions/drawings	Page 41 ▶

# SI 1000 series

Panel mount display / controllers



- ▶ Red 7 digit display
- ▶ RS232 or RS485 Serial outputs
- ▶ VDC or 4-20 mA outputs
- ▶ Low, OK, High lamps and relays
- ▶ Peak Hold

The Si 1000 series is a simple to use, cost effective single channel solution to a wide range of laboratory and industrial linear position monitoring and control applications.

The versatile SI 1100 provides up to 0.1µ resolution when used with Solartron's LVDT Displacement and Gauging sensors. A choice of VDC, 4-20 mA outputs and relays make it easy to communicate with PLC's. RS232 and RS485 serial ports are also standard.

Where long cable runs are required, the SI 1300 is an obvious choice. Two wire loop powered 4-20 mA connection to Solartron's S and SR Series of rugged Displacement Sensors completes a simple to install system with impressive performance. DC/DC operation is also standard for use with DC versions of the S and SR series.

The SI 1500 is a cost effective yet versatile panel mount display for use with Orbit® based Digital Probes, Linear Encoders and Modules.

Dimensions	
Case size (incl. bezel)	H = 48mm x W = 96 x D = 137mm
Panel cut out	H = 44.5mm x W 93mm
Depth behind panel (inc. terminals)	135mm
Display	
Display Type	7 digit red led
Display Update Rate	Up to 10 readings/second
Indicators	Low, OK and High warning lamps
Range	99.9999 to +99.9999
Resolution	1mm to 0.1µm (user selectable)
Bandwidth/response time/sensor reading rate	Up to 100 readings/second
Discrete Inputs	Zero, Peak(+Peak/-Peak/Difference), Hold
Outputs	
Analogue	4-20 mA, -5V to +5V, -10V to +10V, 0V to +5V, 0V to +10V (selectable)
Discrete	Alarm Relay - Open Collector Low, OK and High Relay Response Time = 0.1-9.9 seconds (selectable)
Communications	
Serial Port	RS232 or RS485 Configurable
Power	
Voltage	+24 VDC
Current	850 mA Max
Environmental	
Operating Temperature	10°C to 40°C
Storage Temperature	-10°C to 70°C
Electrical Immunity	EN6100-6-2:2007
Electrical Emissions	EN61000-6-3:
Front Panel Sealing	IP65

# SI 3000 series

Twin axis display / controllers



- ▶ Intuitive menu
- ▶ 2 channel 7 digit colour displays
- ▶ 2 channel analogue colour displays
- ▶ Auto colour change for in/out range
- ▶ Auto course/finite resolution
- ▶ Peak hold facility
- ▶ Data logging facility
- ▶ RS232 output
- ▶ Discrete I/O
- ▶ 4-20mA or DC output

Specifically designed for use with Solartron's high performance Orbit® network, the SI 3500 features an intuitive, menu driven-twin axis display which can be programmed to display readings, set Limits/Alarms, Peak Hold, Track, or act as a Data Logger for inputs from one or two sensors.

LCD Display	
Digital	2 x colour
Analogue	2 x colour horizontal bars
Update speed	40Hz
Display length (mm)	± xx.xxxxx (user selectable)
Display length (ins)	± x.xxxxx (user selectable)
Resolution mm	Down to 0.05µm (user selectable)
Resolution ins	Down to 0.000005" (user selectable)
Keypad	
Membrane type with 9 keys	Print, Zero, Up, Down, Left, Right, Enter, Peak Hold/Track, Menu
Measurement type	A, B, A+B, A-B, (A+B/2), (A-B/2), (B-A/a) X and Y
Data Logging	A, B, A+B, A-B, (A+B/2), (A-B/2), (B-A/a) X and Y 10,000 readings via switch or 1ms to 24hr time interval
Indications	mm/inch, Lower & Upper Limits, Out of Range, Measurement Mode
Power requirement	+24 VDC ± 10%
External I/O	
Serial	RS232 serial port (for printer or PC)
Discrete Output	2 x 3 isolated
Analogue Output	2 channels DC or 4-20mA
Environmental	
Front Panel	IP65
Case	IP51
Rear connection	IP51
EMC	Immunity: EN6100-6-2:2001 Emissions: EN61000-6-3:20011
Storage Temperature (°C)	-20 to +50
Operating Temperature (°C)	0 to +50
Mechanical	
Mounting	Bench top or panel mount
Dimensions WxHxD (mm)	Without bezel 134 x 65x160 With bezel 144 x 74 x 175

# Signal conditioning modules

## OD series

The **OD** series of conditioning units is used to interface with Solartron's sensors to provide different functionality to suit different applications.

The **OD2** is a two wire 4-20mA signal conditioner. It is designed for long distance signal transmission due to low noise susceptibility. A cable break results in no current flow indicating a fault.

The **OD4** (**OD5** is a mains powered equivalent) is a signal conditioning unit powered from a single 10-30VDC supply. The outputs are fully adjustable allowing a range of voltage and current outputs to be selected.



## DRC DIN rail module

The **DRC** is a DIN rail mounted version of the OD4 (see above).



## BICM in line module

The **BICM** provides a simple low cost in line conditioning unit. This is designed for use where the sensor is in a harsh environment as the BICM can be connected up to 10m from the sensor. An IP67 variant of the BICM is also available.



## ATM TTL converter

TTL RS 232 Differential Quadrature is one of the most commonly used methods of communication between Linear Displacement Sensors and Control or Data Acquisition Systems. Its simplicity of Interfacing with programmable systems also makes Solartron's ATM one of the most cost effective.

Module	OD2	OD4	OD5	DRC	BICM	
<b>Power Requirement</b>						
Input Voltage	13-42 VDC	10-30VDC	90-264VAC	10-30VDC	±15VDC	24VDC
Input Current (mA)	<30	140-50	250-100	160-70	±12	24
Frequency (Hz)	-	-	47-63	-	-	-
<b>Sensor Excitation</b>						
Primary voltage (Vrms)	0-9	-	3	-	-	1.2 - 21
Primary frequency (kHz)	5 or 13	2.5 or 5	-	5,10 or 13	-	5
<b>Signal Input</b>						
Input Range	30-530mV/V <sup>1</sup>	55 to 5000mV LVDT full range			up to 3.5	
Input Load (kΩ)	2	2, 10, 100	-	2, 100	100	
Options	-	Forward and reverse polarity, half bridge		see note 2	-	
<b>Signal Output</b>						
Voltage Output	-	Up to ±10				
Current Output	4-20	Up to ±20 into 150Ω load				
Output Ripple	<38μA rms	<1 mV rms	-	-	<14	
Output Offset	Up to 100% on maximum gain (coarse and fine adjustment)					
Temperature Coefficient Gain (%FSO/°C)						<0.03
Temperature Coefficient Offset (%FSO/°C)						<0.02
Warm Up (minutes)	15 minutes					
Linearity (%FSO)						<0.1
Bandwidth (-3dB) (Hz)	25	500Hz, 1kHz			250	
<b>Environmental</b>						
Storage Temperature	-40 to +80	-20 to +80			-	
Operating Temperature	0 to +60			-		
IP rating	65	40	-	None	IP40/67	IP40
<b>Mechanical</b>						
Sensor connections	Terminals	DIN connector	-	Terminals	Solder tag or factory fit for IP67	
Power connections	Terminals	-	IEC320 C14	-	-	
Weight						
Material	ABS	Painted Aluminium Box		Plastic	Plastic or Stainless Steel IP67	
Mounting	Holes	-			DIN rail	-

Module	ATM TTL converter
<b>Measurement</b>	
Sensor types	All Solartron Displacement Sensors
Accuracy (%FSO)	<0.25
Resolution (x4 interpolation)	0.1
Repeatability	sensor dependent
<b>Electrical</b>	
Power	+5 ±0.25 VDC @ 100 mA
Output Signal	A and B, /A and /B TTL square waves RS422 levels
Output frequency (kHz)	50, 100, 125, 250, & 500 (factory selectable)
Bandwidth	100 Hz
<b>Environmental (electronics)</b>	
Sealing	IP43
Operating temperature (°C)	0 to +60
Storage temperature (°C)	-20 to +70

Note 1: For sensors with sensitivity > 250mV/V, an adjustable attenuator is required- contact sales  
 Note 2: Sensor is connected via external screw terminal user can therefore configure options  
 Note 3: For higher environmental levels (and other custom options) contact sales office

**Also see...**  
 Dimensions and drawings Page 40 ▶

Refer to product manual 502724 for details of operation – contact sales office/web site

# S series

## Dimensions (mm)

### Guided Core, Spring Push and Universal Joints

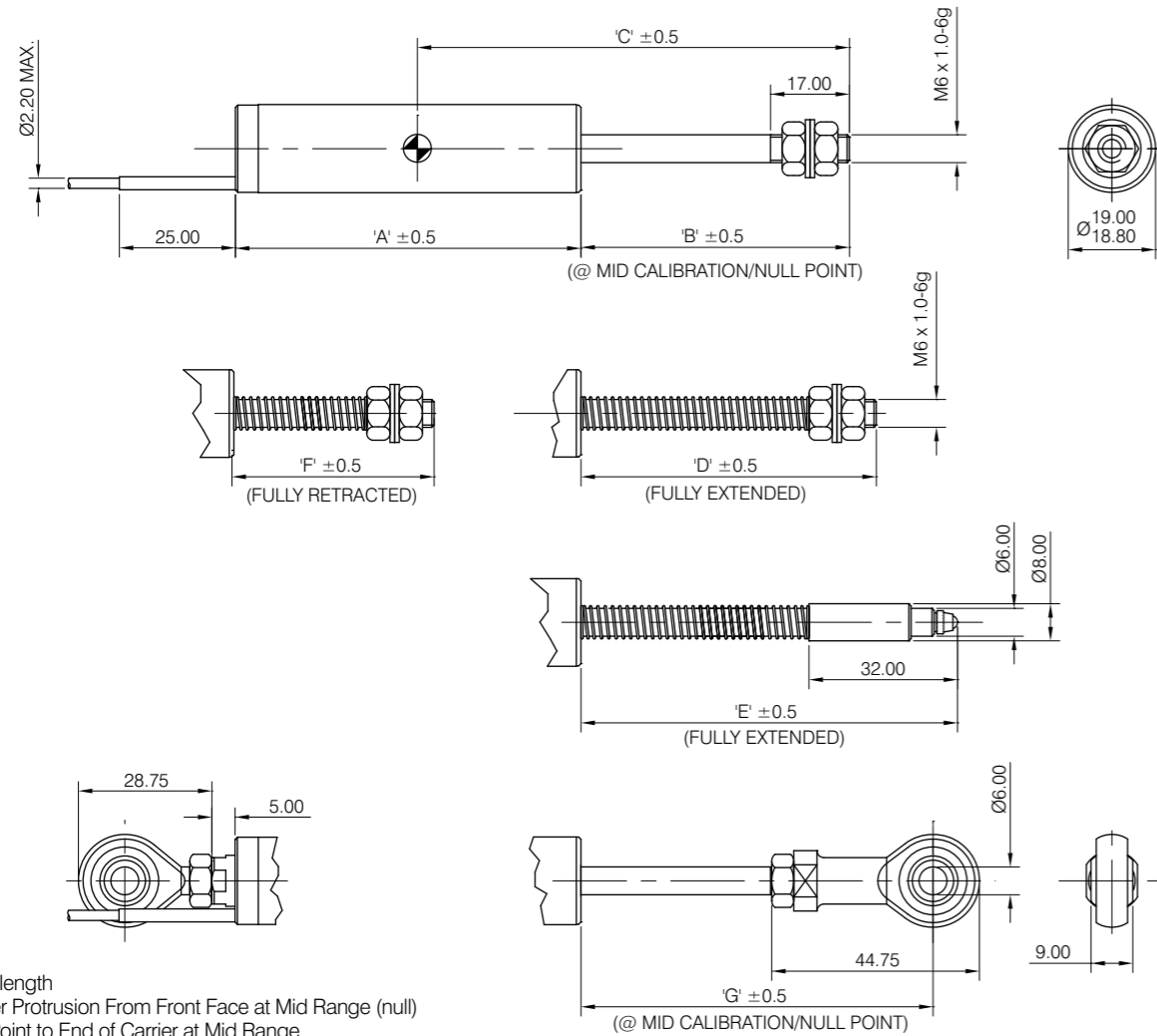

- A = Body length
- B = Carrier Protrusion From Front Face at Mid Range (null)
- C = Null Point to End of Carrier at Mid Range
- D = Carrier Protrusion From Front Face at Fully Out with Spring Fitted
- E = Carrier Protrusion From Front Face at Fully Out with Tip Fitted
- F = Carrier Protrusion From Front Face Fully Retracted
- G = Distance from centre of UJ to front face at Mid Range
- CF = Consult Solartron for this option

Range (mm)		Guided Core, Spring Push and Universal Joints							
LVDT	DC & 4-20mA	LVDT	DC & 4-20mA	All					
		A	A	B	C	D	E	F	G
±2.5	5	55.1	94.0	31.2	56.8	35.7	50.8	24.4	49.5
±5	10	74.6	113.5	38.7	74.0	46.7	61.8	28.4	57.0
±7.5	15	81.8	120.7	41.6	80.5	50.7	65.8	30.2	59.9
±10	20	96.1	135.1	48.4	94.5	61.7	76.8	32.8	66.8
±15	30	110.5	149.4	58.0	111.3	79.7	94.8	34.0	76.3
±25	50	132.0	171.0	70.7	134.8	102.7	117.8	36.4	89.1
±50	100	189.5	228.5	105.7	198.5	160.7	175.8	48.5	124.0
±75	150	239.7	278.7	151.6	269.5	231.7	246.8	69.2	169.9
±100	200	297.2	336.2	182.9	329.5	291.7	CF	71.8	201.2
±150	300	412.1	449.9	291.5	495.5	458.7	CF	122.9	309.5

# S series

## Dimensions (mm)

### Axial Connector / Guided Core

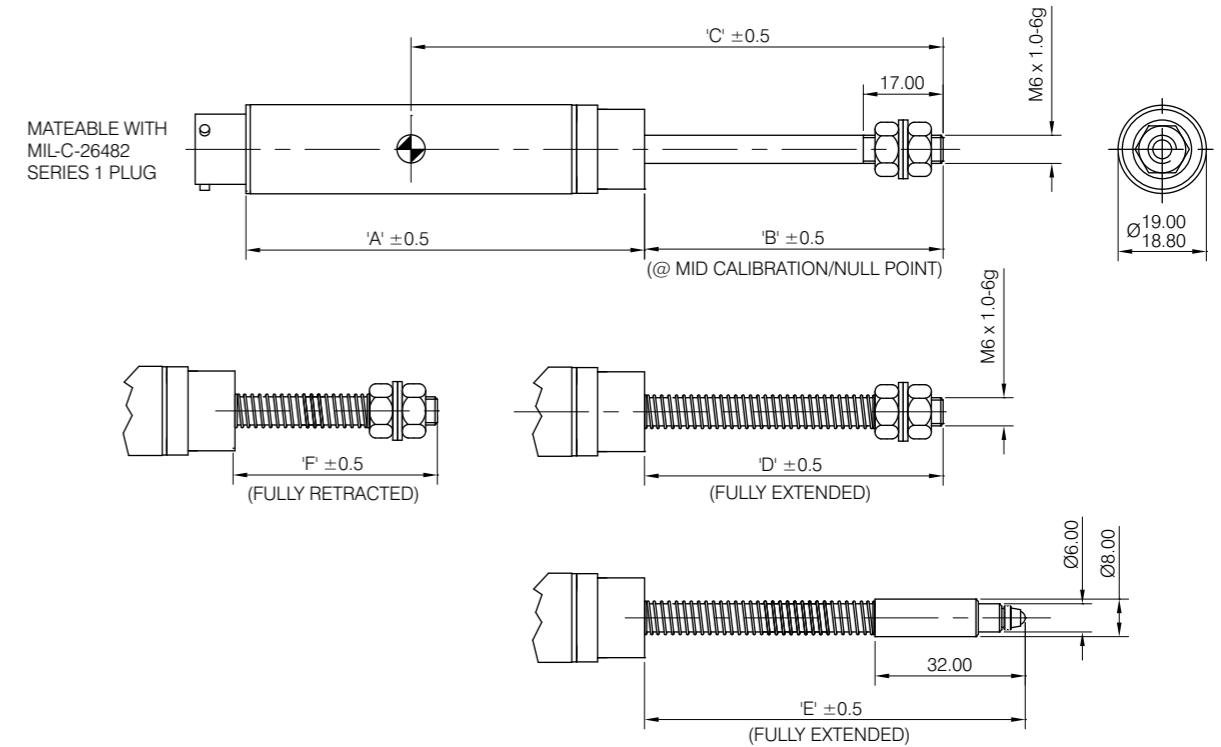

- A = Body length
- B = Carrier Protrusion From Front Face at Mid Range (null)
- C = Null Point to End of Carrier at Mid Range
- D = Carrier Protrusion From Front Face Fully Extended
- E = Carrier Protrusion From Front Face Fully Extended + Tip Fitted
- F = Carrier Protrusion From Front Face Fully Retracted
- CF = Consult Solartron for this option

Range (mm)		Axial Connector Guided Core						
LVDT	DC & 4-20mA	LVDT	DC & 4-20mA	All				
		A	A	B	C	D	E	F
±2.5	5	68.4	101.4	32.6	64.8	40.0	55.1	27.6
±5	10	87.4	118.4	40.0	82.0	51.0	66.1	30.5
±7.5	15	94.4	127.9	42.9	88.5	55.0	70.1	32.4
±10	20	109.4	142.4	49.8	102.5	66.0	81.1	35.0
±15	30	124.4	156.4	59.3	119.3	84.0	99.1	36.1
±25	50	145.4	178.4	72.1	142.8	107.0	122.1	38.6
±50	100	202.4	235.4	107.1	206.5	164.9	180.1	50.7
±75	150	253.4	286.4	153.0	227.5	236.0	251.1	71.4
±100	200	309.4	341.4	184.2	337.5	296.0	CF	73.9
±150	300	424.4	456.3	292.8	503.5	462.0	CF	125.0

## S series dimensions (mm)

### Free Core and Free Core with Carrier

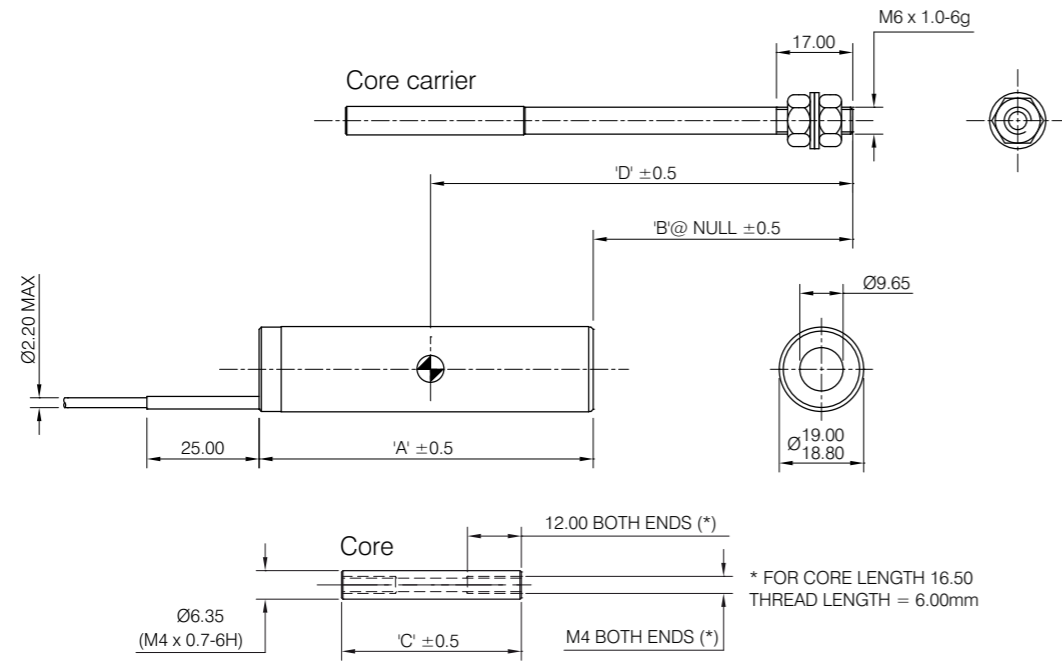

- A = Body length
- B = Carrier Protrusion From Front Face at Mid Range (null)
- C = Core Length
- D = Null Point to End of Carrier at Mid Range

Range (mm)		Free Core and Free Core with Carrier				
LVDT	DC & 4-20mA	LVDT	DC & 4-20mA	All		
		A	A	B	C	D
±2.5	5	33.4	72.4	40.5	16.5	55.3
±5	10	53.0	91.4	48.0	29.0	72.5
±7.5	15	60.1	99.1	50.9	34.0	79.0
±10	20	74.5	113.4	57.8	40.0	93.0
±15	30	88.9	127.8	67.3	37.5	109.8
±25	50	110.4	149.3	80.1	38.5	103.3
±50	100	167.9	206.8	115.0	50.0	197.0
±75	150	218.1	257.1	160.9	50.0	268.0
±100	200	275.6	314.7	192.2	50.0	328.0
±150	300	390.4	429.5	300.8	50.0	294.0

## S series dimensions (mm)

### Axial Connector / Free Core and Free Core with Carrier

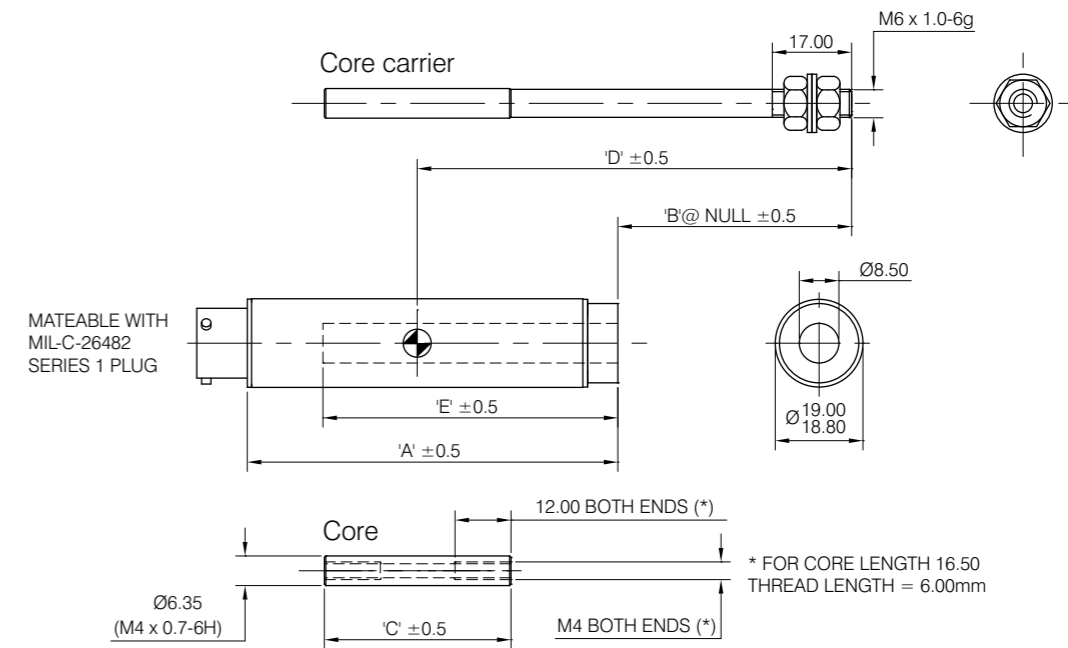

- A = Body length
- B = Carrier Protrusion From Front Face at Mid Range (null)
- C = Core Length
- D = Null Point to End of Carrier at Mid Range
- E = Bore Depth (minimum)

Range (mm)		Axial Connector Free Core and Free Core with Carrier					
LVDT	DC & 4-20mA	LVDT	DC & 4-20mA	All			
		A	A	B	C	D	E
±2.5	5	60.4	93.4	39.0	16.5	63.3	41.4
±5	10	79.4	110.4	47.0	29.0	80.5	62.0
±7.5	15	86.4	119.9	49.0	34.0	57.0	69.1
±10	20	101.4	134.4	56.0	40.0	101.0	83.5
±15	30	116.4	148.4	66.0	37.5	117.3	97.9
±25	50	137.4	170.4	79.0	38.5	141.3	119.4
±50	100	194.4	227.4	114.0	50.0	205.0	176.8
±75	150	245.4	278.4	159.0	50.0	276.0	229.4
±100	200	301.4	333.4	191.0	50.0	336.0	284.6
±150	300	416.4	448.3	299.0	50.0	502.0	399.4



## SR series dimensions (mm)

### Axial Connector / Guided Core

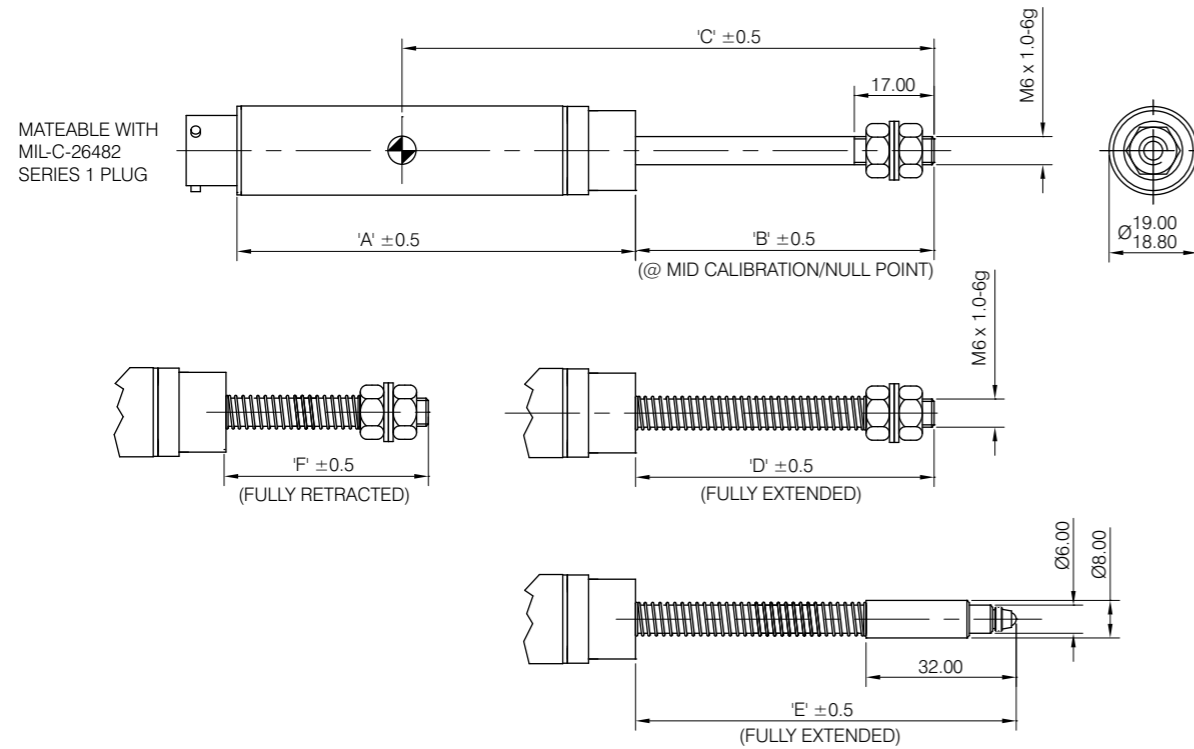

- A = Body length
- B = Carrier Protrusion From Front Face at Mid Range (null)
- C = Core Length
- D = Null Point to End of Carrier at Mid Range
- E = Fully Extended + Tip Attached
- F = Fully Retracted

Range (mm)		Axial Connector Guided Core						
LVDT	DC & 4-20mA	LVD	DC & 4-20mA	All				
		A	A	B	C	D	E	F
±2.5	5	68.4	101.4	31.8	65.0	35.8	50.9	28.1
±5	10	87.4	118.4	39.1	83.1	46.8	61.9	32.4
±7.5	15	94.4	127.9	40.8	88.4	50.8	65.9	31.9
±10	20	109.4	142.4	48.4	103.1	61.8	76.9	36.4
±15	30	120.4	156.4	58.4	120.4	79.8	94.9	38.9
±25	50	145.4	178.4	71.2	143.9	102.8	117.9	40.9
±50	100	202.4	235.4	106.2	207.6	160.8	175.9	52.4
±75	150	253.4	286.4	152.1	278.6	231.8	246.9	73.4

## SR series dimensions (mm)

### Axial Connector / Free Core

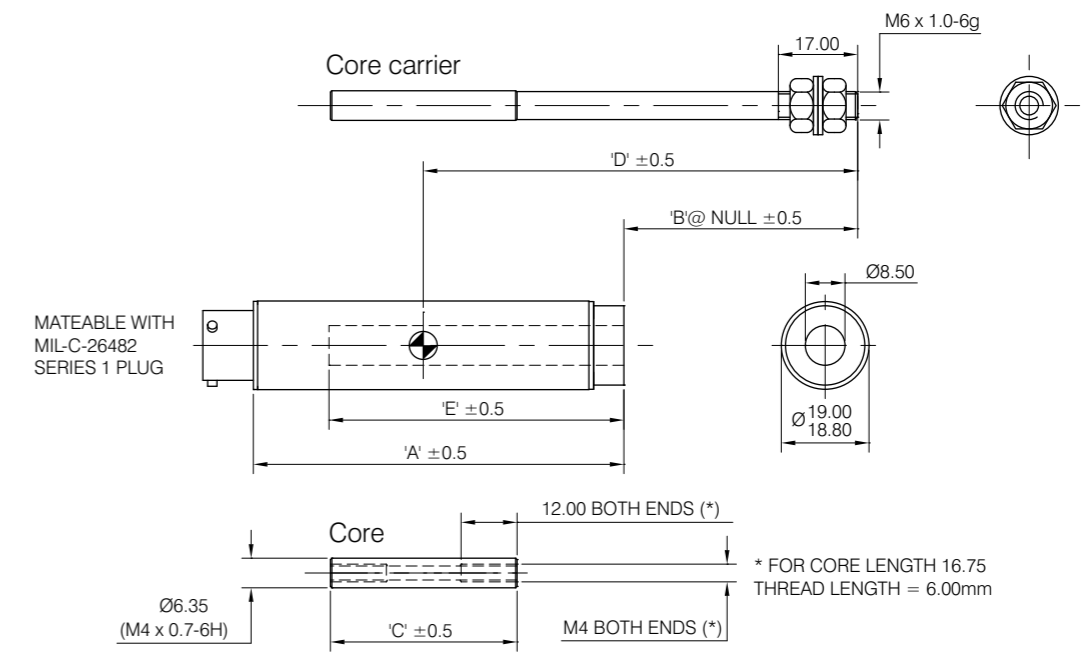

- A = Body length
- B = Carrier Protrusion From Front Face at Mid Range (null)
- C = Core Length
- D = Null Point to End of Carrier at Mid Range
- E = Bore Depth

Range (mm)		Axial Connector Free Core					
LVDT	DC & 4-20mA	LVD	DC & 4-20mA	All			
		A	A	B	C	D	E
±2.5	5	60.4	93.4	37.2	16.75	63.4	44.2
±5	10	79.4	110.4	44.5	29.00	80.5	63.2
±7.5	15	86.4	119.9	46.2	31.50	85.8	70.2
±10	20	101.4	134.4	53.8	39.00	100.5	84.2
±15	30	112.4	148.4	63.8	37.50	117.8	98.2
±25	50	137.4	170.4	76.6	38.50	141.3	120.2
±50	100	194.4	227.4	111.6	50.00	205.0	178.2
±75	150	245.4	278.4	157.5	50.00	276.0	228.2

## SR series dimensions (mm)

Axial Connector / Captive Guided Core  
MI Cable / Captive Guided Core

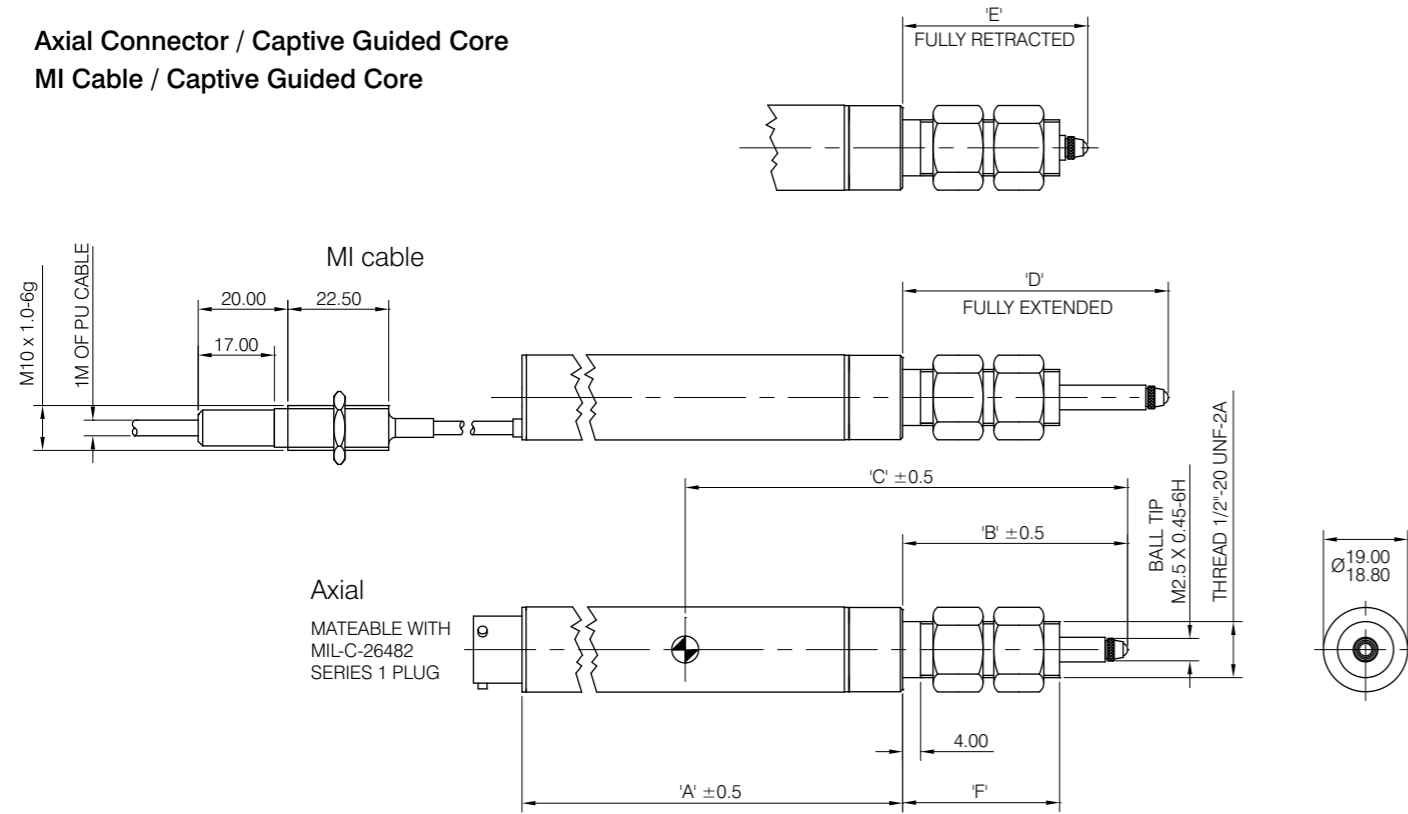

A = Body length  
B = Carrier Protrusion From Front Face at Mid Range (null)  
C = Null Point to End of Carrier at Mid Range  
D = Fully Extended  
E = Fully Retracted  
F = Adaptor Length

Range (mm)		Axial Connector Captive Guided Core						
LVDT	DC & 4-20mA	LVDT	DC & 4-20mA	All				
		A	A	B	C	D	E	F
±2.5	5	65.9	98.9	44.7	76.4	48.7	41.1	35.0
±5	10	84.9	115.9	48.0	89.5	56.2	41.3	35.0
±7.5	15	91.9	124.4	50.2	95.3	60.7	41.3	35.0
±10	20	106.9	139.9	94.3	146.5	106.2	82.3	76.0
±15	30	117.9	153.9	101.8	161.3	121.2	82.3	76.0
±25	50	142.9	175.9	112.5	182.3	140.2	82.3	76.0

Range (mm)		MI Cable Captive Guided Core						
LVDT	DC & 4-20mA	LVDT	DC & 4-20mA	All				
		A	A	B	C	D	E	F
±2.5	5	61.0	99.0	45.3	76.4	48.7	41.0	35.0
±5	10	80.0	118.0	49.2	89.5	56.2	41.0	35.0
±7.5	15	87.5	125.5	51.0	95.3	60.7	41.0	35.0
±10	20	102.0	140.0	95.0	146.5	106.2	82.0	76.0
±15	30	116.0	154.0	102.9	161.3	121.2	82.0	76.0
±25	50	138.0	176.0	113.2	182.8	140.2	82.0	76.0

## SR series dimensions (mm)

MI Cable / Guided Core

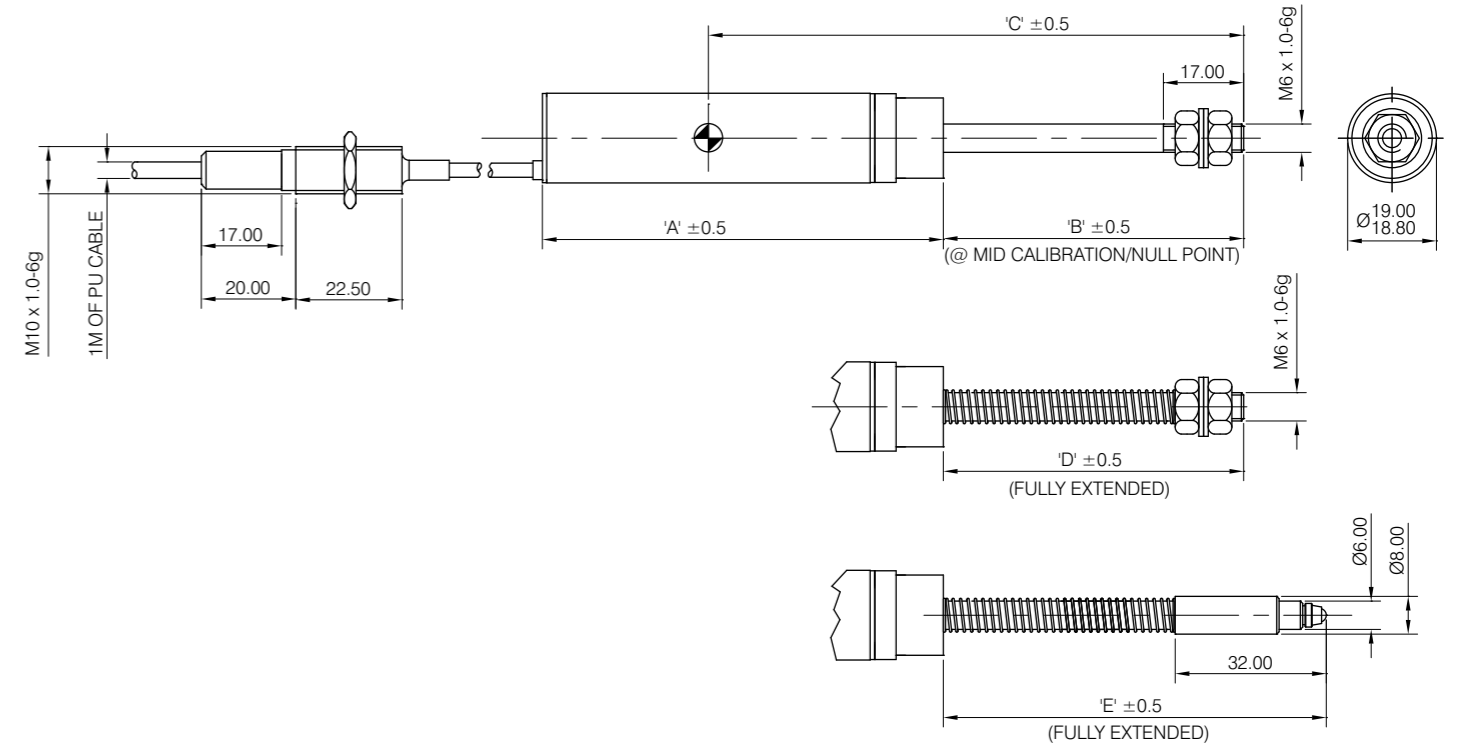

A = Body length  
B = Carrier Protrusion From Front Face at Mid Range (null)  
C = Null Point to End of Carrier at Mid Range  
D = Fully Extended + Spring Attached  
E = Fully Extended + Tip Attached

Range (mm)		MI Cable Guided Core					
LVDT	DC & 4-20mA	LVDT	DC & 4-20mA	All			
		A	A	B	C	D	E
±2.5	5	63.5	101.5	32.4	66.0	35.8	50.9
±5	10	82.5	120.5	40.3	83.1	46.8	61.9
±7.5	15	90.0	128.0	41.6	88.4	50.8	65.9
±10	20	104.5	142.5	49.1	103.1	61.8	76.9
±15	30	118.5	156.5	59.5	120.4	79.8	94.9
±25	50	140.5	178.5	71.8	143.9	102.8	117.9
±50	100	197.5	235.5	107.2	207.6	160.8	175.9
±75	150	248.5	286.5	152.4	278.6	231.8	246.9

## SR series dimensions (mm)

### MI Cable / Free Core

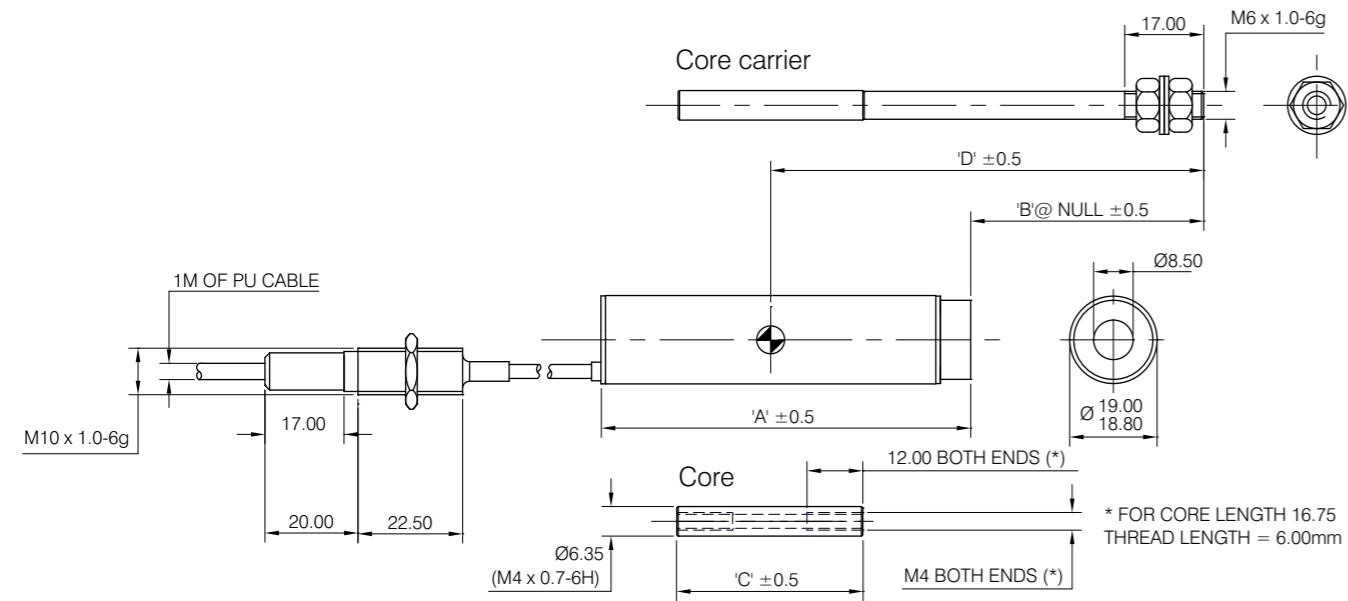

A = Body length  
 B = Carrier Protrusion From Front Face at Mid Range (null)  
 C = Core Length  
 D = Null Point to End of Carrier at Mid Range

Range (mm)		MI Cable Free Core				
LVDT	DC & 4-20mA	LVDT	DC & 4-20mA	All		
		A	A	B	C	D
±2.5	5	55.6	93.4	37.8	16.75	63.4
±5	10	74.5	112.5	45.7	29.00	80.5
±7.5	15	82.0	120.0	47.0	31.50	85.8
±10	20	96.5	134.5	54.5	39.00	100.5
±15	30	110.5	148.5	64.9	37.50	117.8
±25	50	132.5	170.5	77.2	38.50	141.3
±50	100	189.5	225.2	112.6	50.00	205.0
±75	150	240.5	278.5	157.8	50.00	276.0

## Optimum series dimensions (mm)

### Free core

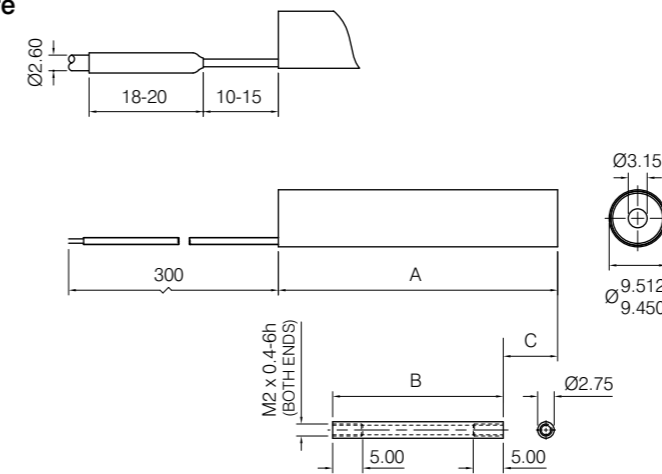

Type	A	B	C at null
OP1.5	20.60	11.00	4.80
OP6.0	46.50	28.40	9.05
OP12.5	83.50	50.80	16.35

### Guided core

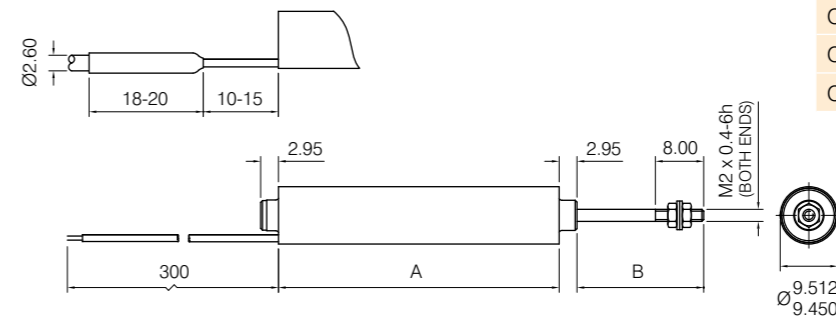

Type	A	B at null
OP1.5	20.60	14.10
OP6.0	46.50	21.00
OP12.5	83.50	31.70

### Universal joints

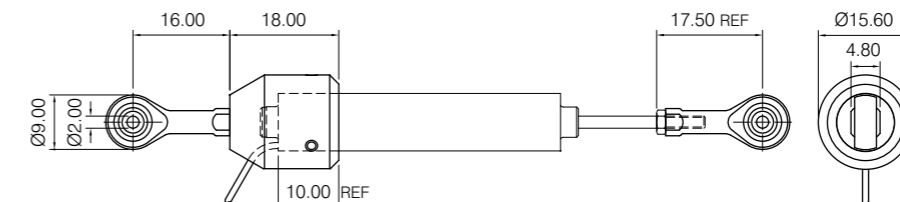

## SM series dimensions (mm)

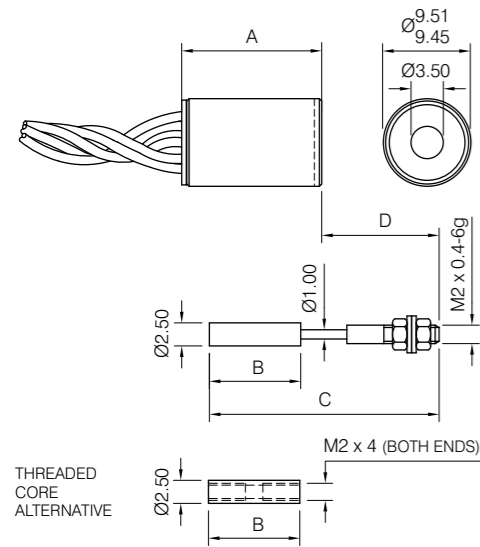

Type	A	B	C	D at null
SM1	15.10/15.25	9.90	24.90	12.70
SM3	34.90/35.05	20.60	42.60	15.30

## MD dimensions (mm)

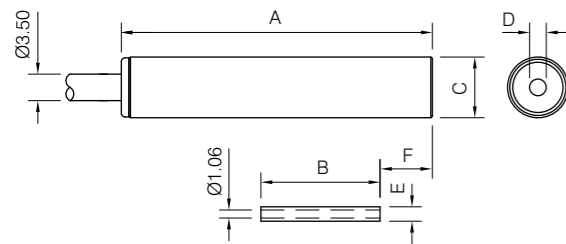

Type	A	B LVDT	B H/B	C	D	E	F at null
M6D1 / M6DH1	28.00	11.00	10.30	Ø6h6	Ø1.95	Ø1.60	2.00
MD1 / MD1H	28.00	11.00	8.85	Ø8h6	Ø2.20	Ø1.90	3.00
MD2.5 / MD2.5H	41.00	15.70	15.00	Ø8h6	Ø2.20	Ø1.90	6.90
MD5 / MD5H	49.00	21.20	18.40	Ø8h6	Ø2.20	Ø1.90	8.40
MD10 / MD10H	68.00	24.40	29.00	Ø8h6	Ø2.20	Ø1.90	16.40

## DF series dimensions (mm)

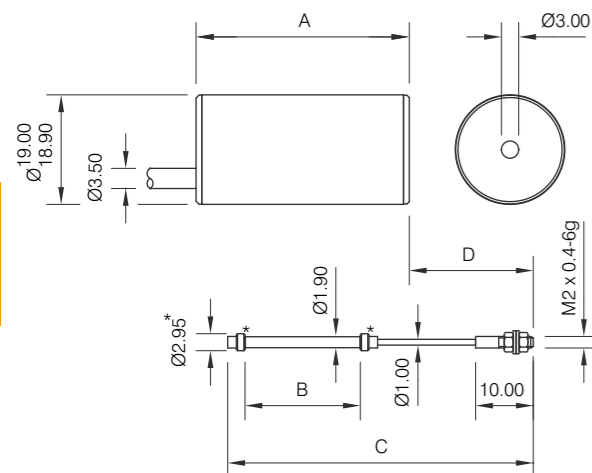

Type	A	B	C	D at null
M6D1 / M6DH1	28.00	11.00	10.30	Ø6h6
MD1 / MD1H	28.00	11.00	8.85	Ø8h6
MD2.5 / MD2.5H	41.00	15.70	15.00	Ø8h6
MD5 / MD5H	49.00	21.20	18.40	Ø8h6

## LE Linear Encoders dimensions (mm)

### IP50 versions

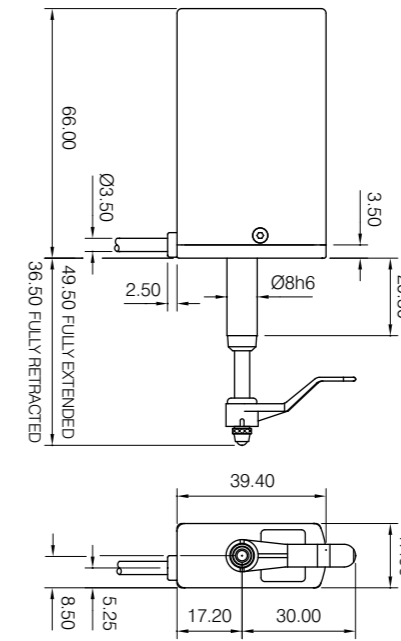

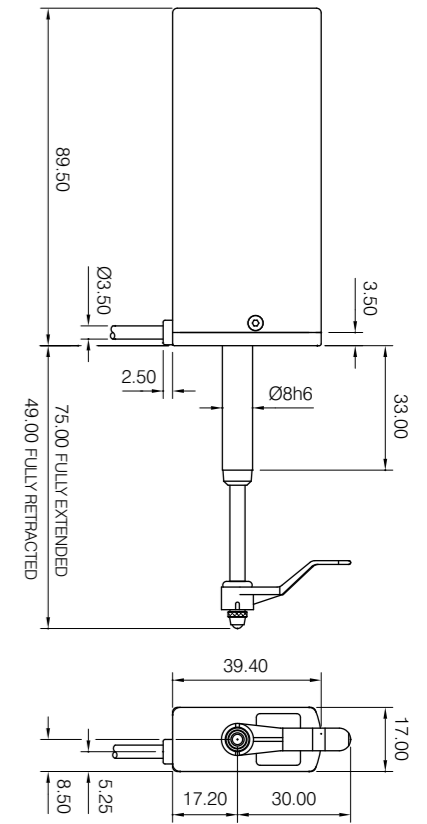

LE/12/S



LE/25/S

### IP60 versions

 Air inlet nozzle for pneumatic (P) versions

 Lift for spring (S) versions

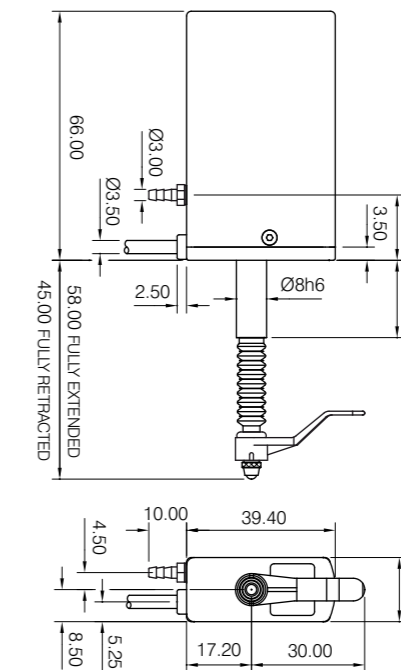

LE/12/S and LE/12/P

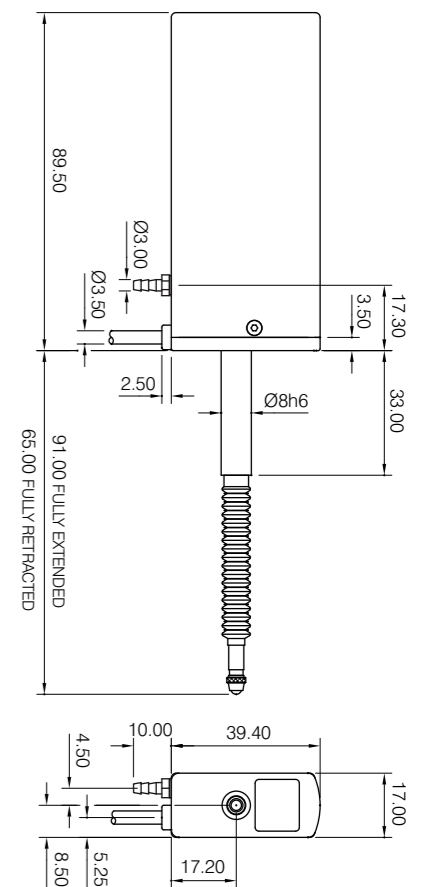

LE/25/S and LE/25/P

## Signal conditioning modules dimensions (mm)

### OD series

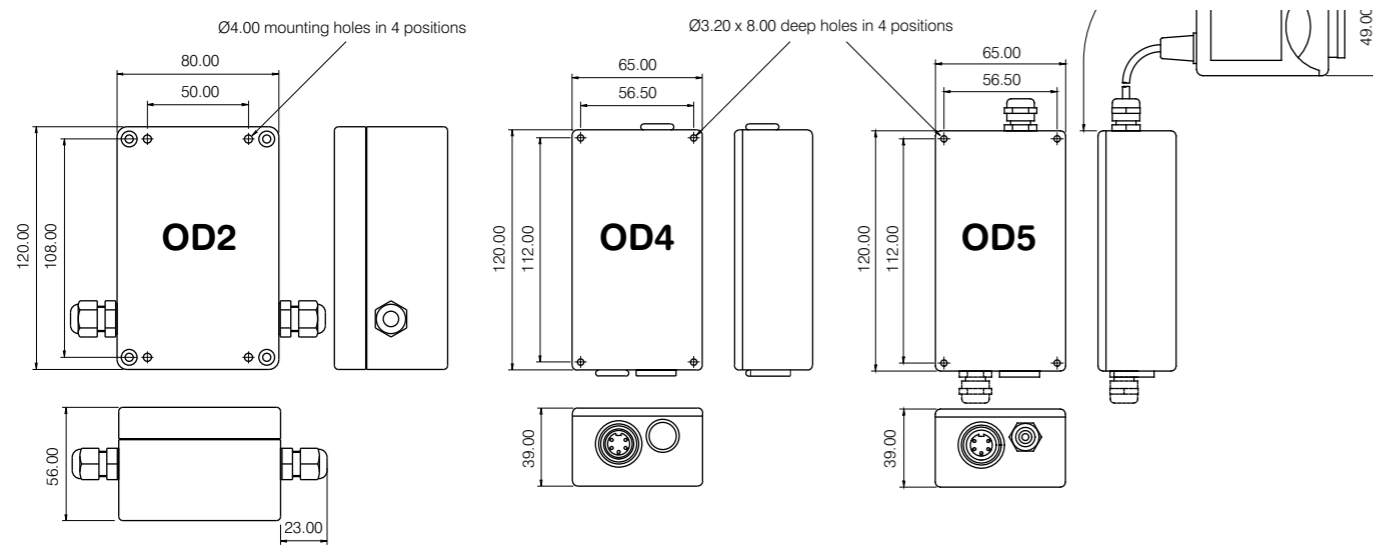

### ATM TTL converter

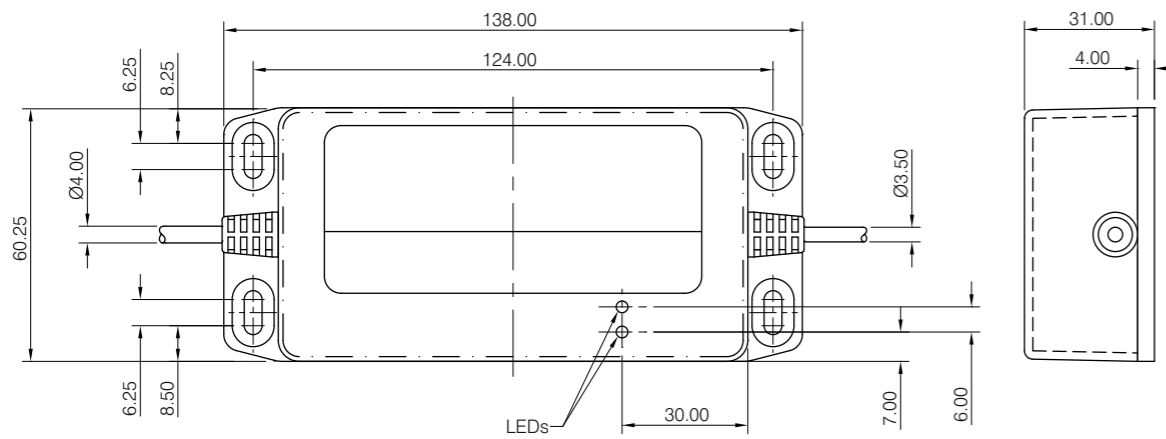

### BICM in line module

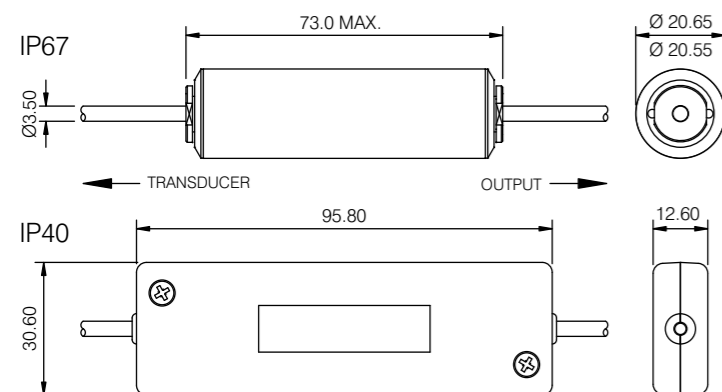

### DRC DIN rail module

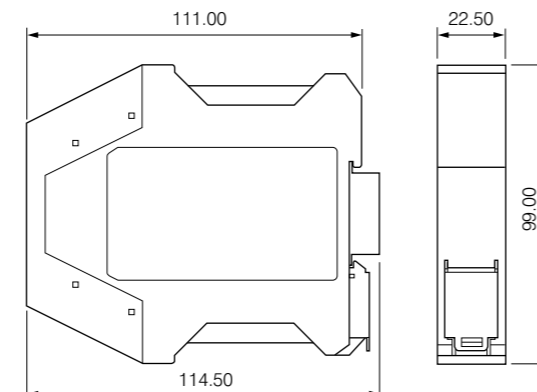

## Orbit® interface components dimensions (mm)

### PIE (Probe Interface Electronics)

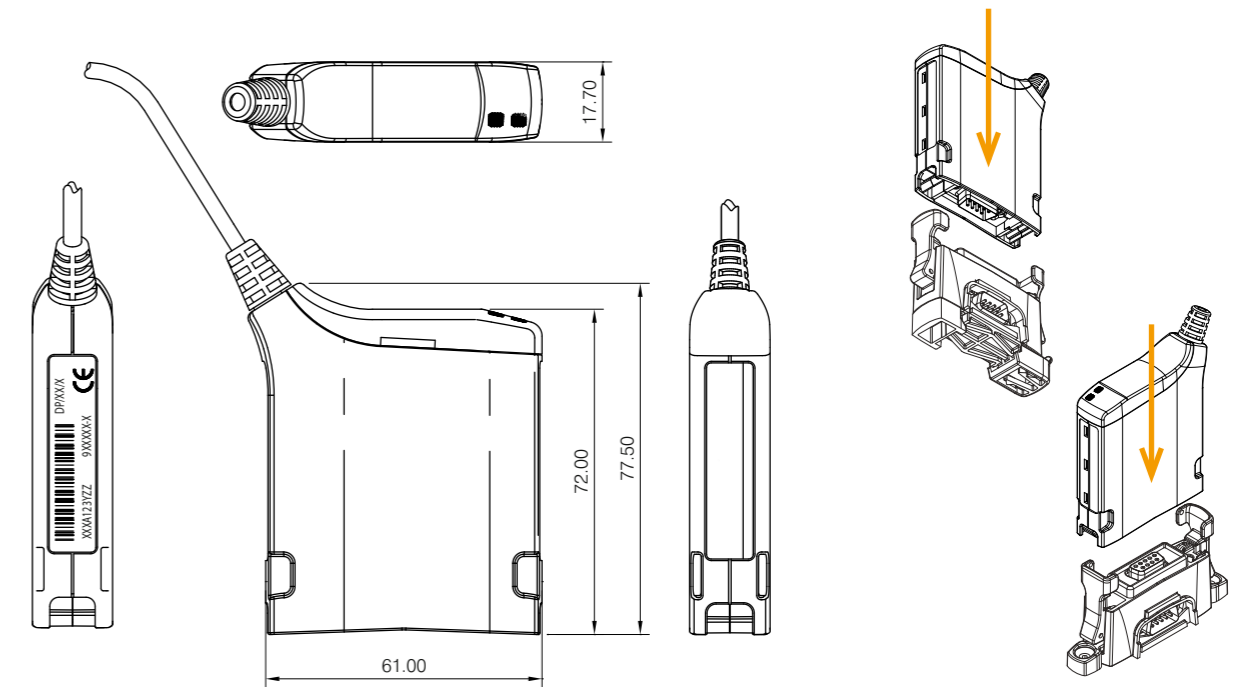

### T-CON Orbit network connector

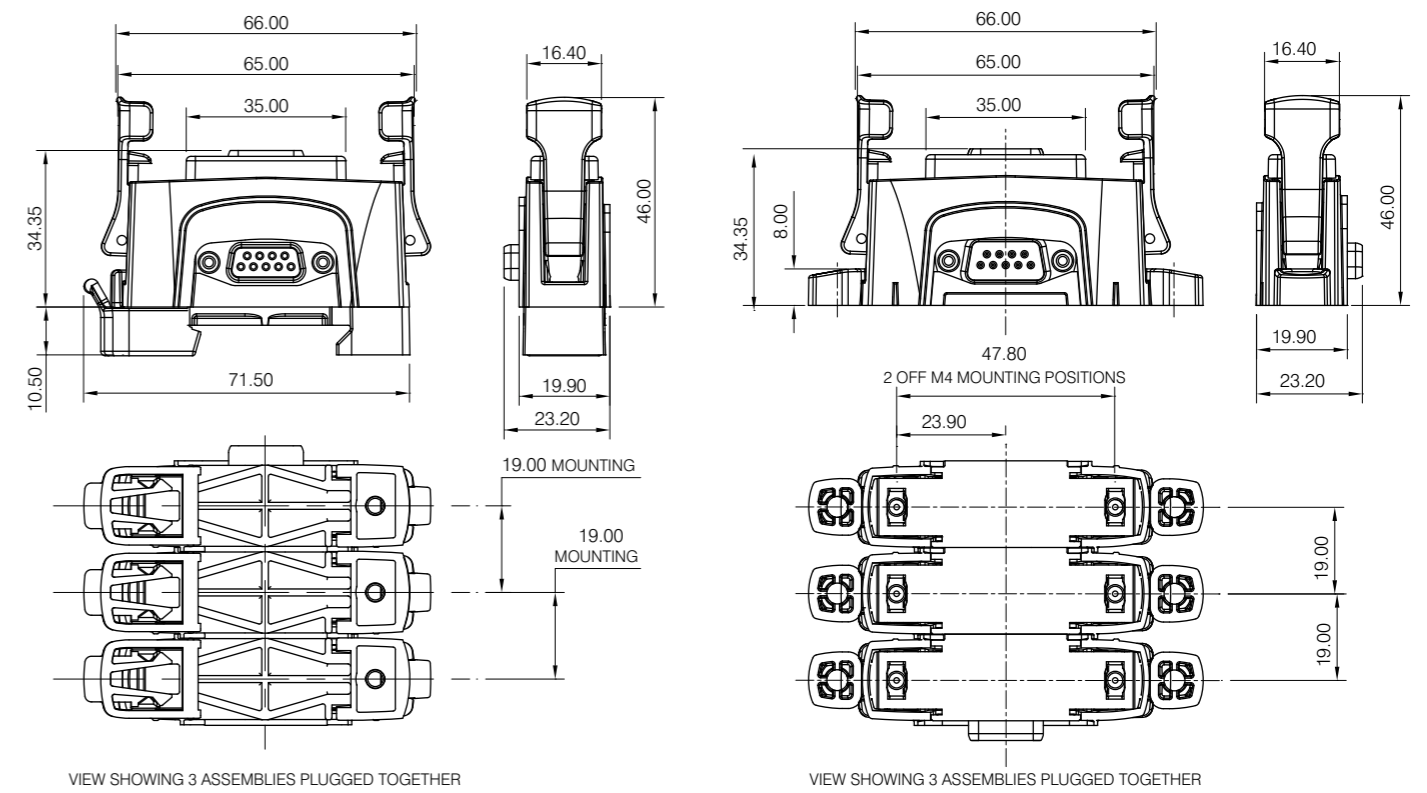

T-CON with 32 mm DIN raise connector

T-CON with mounting feet option

## Orbit® interface components dimensions (mm)

PSIM (Power Supply Interface Module)

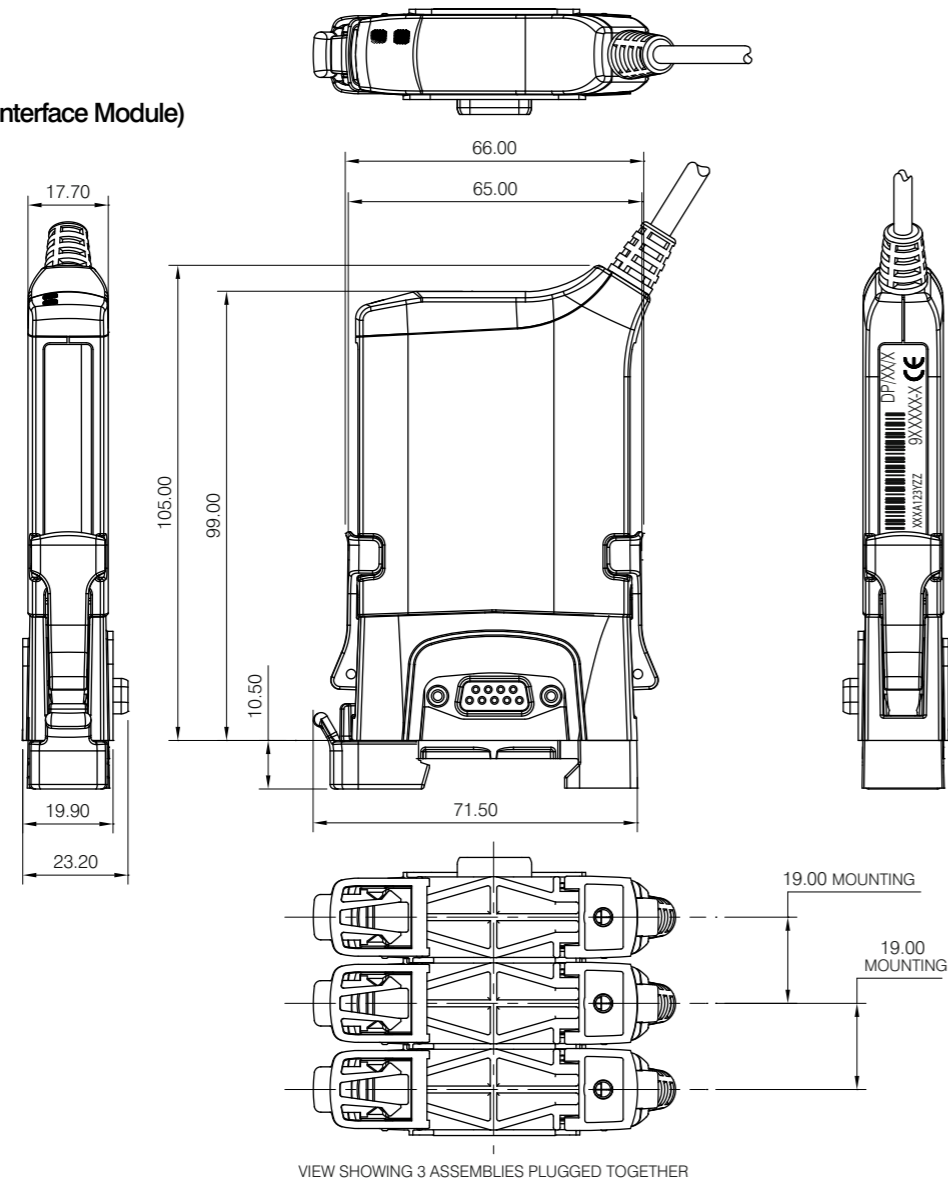

PSIM transformer

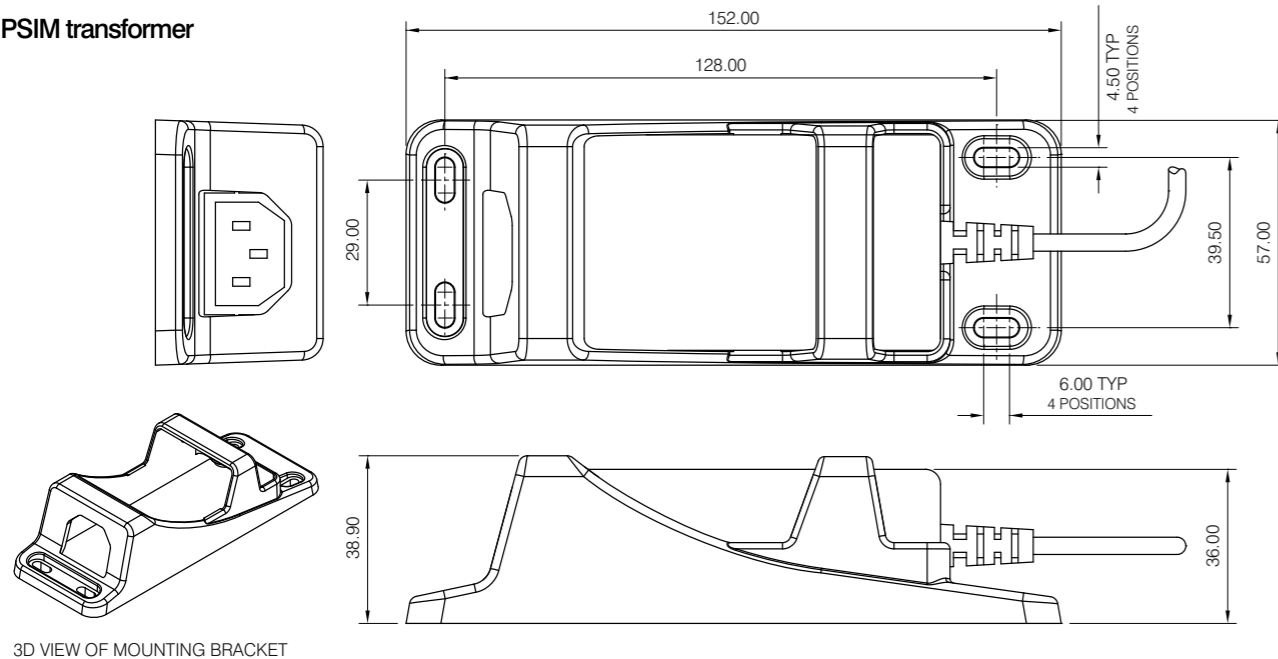

3D VIEW OF MOUNTING BRACKET

## Other Solartron sensor solutions



### Gauging Sensors

Our Specialist Gauges make precision measurements of miniature parts, bores and cavities a simple and reliable process.

- ▶ Measurement ranges from 0.5mm to 10mm
- ▶ Resolution down to 0.01µm
- ▶ Repeatability: <0.25µm
- ▶ IP65 protection
- ▶ LVDT and half bridge
- ▶ Pneumatic or spring actuation
- ▶ Range of changeable tips

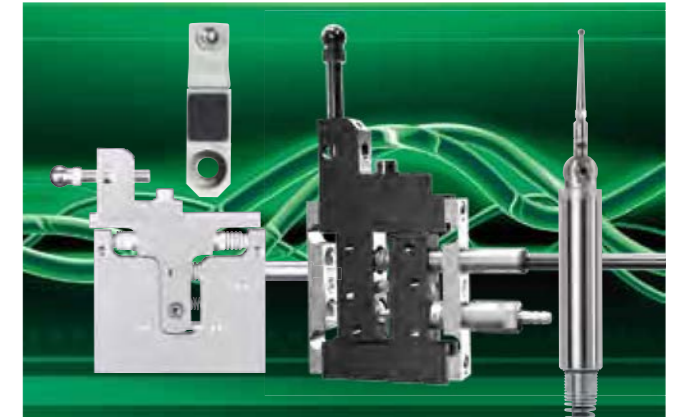

### Specialist Gauging Sensors

Our extensive range includes Inductive and Optical Encoder Probes and probes with integrated electronics.

- ▶ Measurement ranges from 0.5mm to 100mm
- ▶ Accuracy to 0.1% of reading (inductive) or 0.4µm for encoders
- ▶ Resolution down to 0.01µm or better
- ▶ Probe diameters from 6mm
- ▶ LVDT or Half Bridge
- ▶ Spring push, Pneumatic push or Vacuum retract
- ▶ Precision linear bearings

## GEMCO Series Magnetostrictive Displacement Sensors

### S953

- ▶ 25.4 mm to 7620 mm measuring range
- ▶ <0.01% linearity
- ▶ Vibration resistant up to 30G
- ▶ Shock Resistant up to 1000G
- ▶ Tricolour diagnostic LED
- ▶ All standard current and voltage outputs
- ▶ RS, VP, CP and TP Digital outputs
- ▶ IP 68
- ▶ Protective housings for harsh environments



The S953 VMAX Linear Displacement Transducer is the ideal solution for automation solutions requiring accurate feedback of continuous position. It is especially recommended in environments where vibrations, extreme temperature and contaminants are present. The S953 is an ideal solution when velocity and position need to be incorporated into the automation control system process.

### S955

- ▶ 100 mm to 4572 mm measuring range
- ▶ <0.05% linearity
- ▶ Non-contact applications
- ▶ Analogue voltage and current outputs
- ▶ Analogue zero and span adjustable
- ▶ Digital RS, VP and CP outputs
- ▶ Quadrature outputs
- ▶ Tricolour diagnostic LED
- ▶ IP 67 (IP 68 optional)



Designed for OEMs as an alternative to limit switches, proximity sensors or linear potentiometers, the S955 Brik Linear Displacement Transducer is an economical solution for monitoring continuous position. The sensing element and electronics are housed in a streamlined anodized aluminium extrusion. Position is determined by a magnet, linearly guided over the sensing element.

## Sales offices

### UK

Solartron Metrology  
Steyning Way, Bognor Regis  
West Sussex, PO22 9ST

### Sales

Tel: +44 (0)1243 833333  
Fax: +44 (0)1243 833332  
Email: sales.solartronmetrology@ametek.com

### Reception

Tel: +44 (0)1243 833300  
Fax: +44 (0)1243 861244

### France

AMETEK SAS  
Solartron Metrology Division  
Rond point de l'épine des champs  
Buroplus Bat D  
Elancourt, 78990 France  
Tel: +33 (0)1 30 68 89 50  
Fax: +33 (0)1 30 68 89 99  
Email: info.solartronmetrology@ametek.fr

### Germany

AMETEK GmbH  
Solartron Metrology Division  
Rudolf-Diesel-Strasse 16  
40670 Meerbusch  
Tel: +49 (0) 2159 9136 500  
Fax: +49 (0) 2159 9136 505  
Email: vertrieb.solartron@ametek.de

### China

Ametek Commercial Enterprise (Shanghai) Co., Ltd  
No.155 Puhui Road  
Jui Ting Economic Development Zone  
Shanghai, 201615, China  
Tel: +86 21 5763 2509  
Fax: +86 21 5866 0969 Ext. 261/262  
Email: china.solartronmetrology@ametek.com

### USA

Solartron Metrology  
USA Central Sales Office  
915 N. New Hope Road, Suite C  
Gastonia, NC 28054  
Tel: +1 800 873 5838  
Email: usasales.solartronmetrology@ametek.com

### USA East

AL, CT, DE, DC, FL, GA, KY, ME, MD, MA, MS,  
NH, NY, NC, PA, RI, SC, TN, VT, VA, WV  
Tel: +1 704 488 0384

Email: usaeast.solartronmetrology@ametek.com

### USA Industrial Belt

MI, Ohio (North of 170)  
Tel: +1 810 877 2394  
Email: usaindustrialbelt.solartronmetrology@ametek.com

### USA Midwest/Northwest

ID, IL, IN, IA, KS, MN, MO, MT, NE, ND, OR, SD,  
Ohio (South of 170), WA, WI, WY  
Tel: +1 248 390 0632  
Email: usamidwest.solartronmetrology@ametek.com

### USA Southwest

AZ, AR, CA, CO, LA, NV, NM, OK, TX, UT, Mexico  
Tel: +1 281 216 3043  
Email: usasouthwest.solartronmetrology@ametek.com

### USA Technical Support

Tel: +1 800 772 2702  
Email: usatech.solartronmetrology@ametek.com

### India

AMETEK Instruments India Private Limited  
1st Floor, Left Wing  
Prestige Featherlite Tech Park  
Plot #148, EPIP II Phase  
Whitefield, Bengaluru 560066  
Karnataka, India  
Tel: +91 80 6782 3200  
Fax: +91 80 6782 3232

## Agents and distributors

### Argentina

ARO S.A.  
Tel: +54 (0)11 4331 5766 / 4503  
Fax: +54 (0)11 4331 3572  
Email: info@aroline.com.ar  
Web: www.aroline.com.ar

### Australia & New Zealand

QC Systems Pty Ltd  
Tel: +61 (0)3 8488 8222  
Fax: +61 (0)3 8488 8100  
Email: sales@qcsystems.com.au  
Web: www.qcsystems.com.au

### Austria

Elsinger Electronic Handel GmbH  
Tel: +43 1 979 465 10  
Fax: +43 1 979 4077  
Email: office@elsinger.at  
Web: www.elsinger.at

### Benelux

Dimed NV  
Tel: +32 3 236 64 65  
Fax: +32 3 236 64 62  
Email: info@dimed.be  
Web: www.dimed.be

### Brazil

MG-EXIM Técnica Ltda  
Tel: +55 (11)4337 1257  
Fax: +55 (11)4122 3458  
Email: vendas@mg-exim.com.br  
Web: www.mg-exim.com.br

### Canada

Hoskin Scientific Ltd  
Burlington  
Tel: +1 905 333 5510  
Fax: +1 905 333 4976  
Email: salesb@hoskin.ca  
Montreal  
Tel: +1 514 735 5267  
Fax: +1 514 735 3454  
Email: salesm@hoskin.ca  
Vancouver  
Tel: +1 604 872 7894  
Fax: +1 604 872 0281  
Email: salesv@hoskin.ca  
Web: www.hoskin.ca

### Czech Republic

K-Pro soft, spol. s.r.o.  
Tel: +420 417 820 580  
Fax: +420 417 532 515  
Email: kprosoft@kprosoft.cz  
Web: www.kprosoft.cz

### Finland

Aseko Oy Electronics Division  
Tel: +358 10 400 1012  
Fax: +358 10 400 1200  
Email: info@aseko.fi  
Web: www.aseko.fi

### Hungary

Adroni Bt.  
Tel: +36 1 214 64 28  
Fax: +36 30 438 08 43  
Email: afellner@t-email.hu  
Web: www.adroni.eu

### Israel

Globus Technical Equipment Ltd  
Tel: +972 9 9560444  
Fax: +972 9 9560202  
Email: office@globus.co.il  
Web: www.globus.co.il

### Italy

Tecnosens S.P.A.  
Tel: +39 030 3534144  
Fax: +39 030 3530815  
Email: info@tecnosens.it  
Web: www.tecnosens.it

### Japan

Yashima Import & Export Co. Ltd  
Tel: +81 (0)3 3588 6463  
Fax: +81 (0)3 3588 6471  
Email: info@ybk.co.jp  
Web: www.ybk.co.jp

### Korea

Hanse Precision Ltd  
Tel: +82 31 477 6400  
Fax: +82 31 477 6404  
Email: hsps@hsps.co.kr  
Web: www.hsps.co.kr

### Malaysia

SciGate Automation (M) Sdn Bhd  
Tel: +03 7804 7522  
Fax: +03 7804 7422  
Email: sales@scigate.com.sg  
Web: www.scigate.com.sg

### Norway

Semitronic AS  
Tel: +47 21 37 87 20  
Fax: +47 22 91 75 01  
Email: firmapost@semitronic.no  
Web: www.semitronic.no

### Poland

Contact German office

### Portugal

Maio, Carmo & Martins, Lda.  
Tel: +351 227 538 604  
Fax: +351 227 538 606  
Email: info@mcm-electronics.com  
Web: www.mcm-electronics.com

### Russia

OOO UNIPROM Ltd  
Tel: +7 9312 739792  
Fax: +7 8312 739801  
Email: sales@uni-prom.ru  
Web: www.uni-prom.ru

### Singapore

SciGate Automation (S) Pte Ltd  
Tel: +65 6561 0488  
Fax: +65 6562 0588  
Email: sales@scigate.com.sg  
Web: www.scigate.com.sg

### South Africa

Reef Diamond Techniques  
Tel: +27 11 493 0991  
Fax: +27 11 493 9044  
Email: reefdia@mweb.co.za  
Web: www.reefdiamond.co.za

### Spain

Medel Cadena SA  
Tel: +34 932 966 294  
Fax: +34 934 315 697  
Email: info@medelcadenacom.com  
Web: www.medelcadenacom.com

### Sweden

Amtele AB  
Tel: +46 (0)8 5564 6600  
Fax: +46 (0)8 5564 6610  
Email: amtele@amtele.se  
Web: www.amtele.se

### Switzerland

QSS Quality Systems Solutions GmbH  
Tel: +41 44 2420 000  
Fax: +41 44 2420 010  
Email: info@qss-solutions.ch  
Web: www.qss-solutions.ch

### Taiwan

Zimmerman Scientific Co., Ltd  
Tel: +886 2 2752 7075  
Fax: +886 2 2771 9415  
Email: zimmerman@ms1.hinet.net  
Website: www.zimmerman.com.tw

### Thailand

Katanya Supply Co. Ltd  
Tel: +66 (02) 334 3718  
Fax: +66 (02) 334 3719  
Email: contact@katanyagroup.com  
Web: www.katanyagroup.com

### Tunisia

Contact French office

### Turkey

Bilginoglu Endustri Malzemeleri  
Sanayi ve Ticaret A.S.  
Headquarters  
Tel: +90 232 433 72 30 (pbx)  
Fax: +90 232 457 37 69  
Istanbul Office and Showroom  
Tel: +90 212 612 55 45  
Fax: +90 212 612 65 85  
Email: info@bilginoglu-endustri.com.tr  
Web: www.bilginoglu-endustri.com.tr

### Vietnam

Vecomtech  
Tel: +84 4 754 9061  
Fax: +84 4 754 9063  
Email: sales@vecomtech.com  
Web: www.vecomtech.com



**QSS Quality Systems Solutions GmbH**

Aemetstrasse 5  
CH-8344 Bäretswil  
T 0041 44 242 0000  
F 0041 44 242 0010  
info@qss-solutions.ch  
www.qss-solutions.ch



Q 09540

Solartron Metrology pursues a policy of continuous development. Specifications in this document may therefore be changed without notice.  
DC2012/01/E

www.solartronmetrology.com



# Displacement sensors

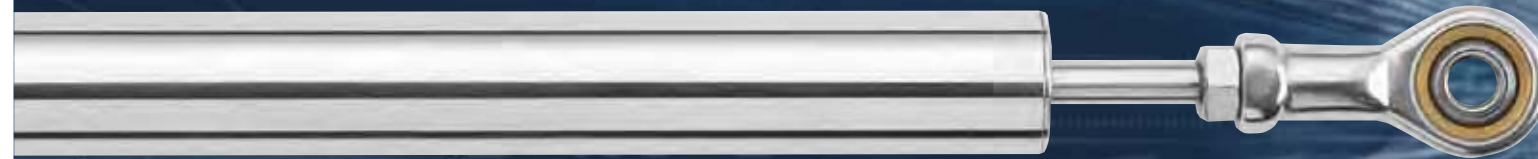

including **myLVDT** A special kind of service

